

Full control of your HVAC system with a tailor-made **MCX solution**

MCX Programmable Controllers

3

**programmability
levels**

to help you perform
both standard and
custom control
software algorithms.



Unique versatility with open standards



Ideal for controlling a wide range of commercial air conditioning applications the open standards compliant MCX unit adds a new level of flexibility and control to application designers. Open programming standards allow you to take full control of your applications such as chillers, rooftop units, air-handling units, close control, shelter units and heat pumps.

What you get

Open programming platform

High-end design with flexible graphical display

What it means

Freedom of choice. Adapt the electronics to your application, not vice versa

A strong impression of product differentiation and ease of use

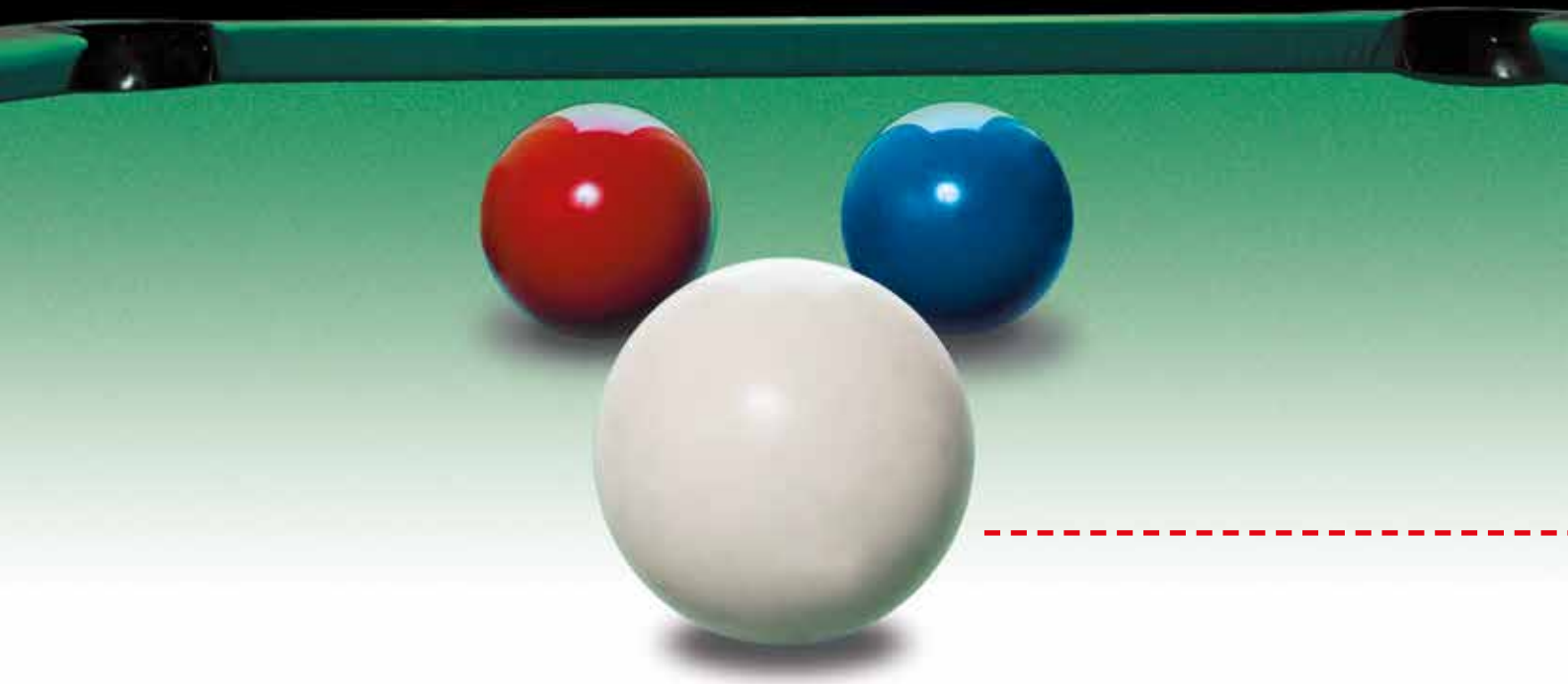

You call the shots

One controller with maximum flexibility makes engineering and development easier than ever. The new, open standards compliant MCX controller from Danfoss provides ultimate software control, allowing you to tailor the performance of your airconditioning system to your exact requirements.

Easy to program using the C programming language, the MCX controller provides unique versatility and freedom compared to proprietary systems.

All units are delivered with a low-level operating system including hardware drivers, services, as well as a virtual machine. Connections to peripheral equipment take place via open standard protocols that enable easy integration with

electromechanical components and building management systems.

Application development options include:

- C-editor and user interface editor
- MCX compiler and debugger
- MCX PC simulator
- Data analysis
- MODBUS PC communication interface

If you do not require full programmability, the MCX is also available with a number of standard applications that offer an exceptional level of customisation.





Easy integration with building management systems

The MCX product range offers a wide range of communication options based on open standards:

- Integration with Building Management System via MODBUS directly
- System integration with other protocols, e.g. LONWORKS and BACnet
- Web pages for internet or intranet access
- Remote access via modem or MODBUS over Ethernet
- Data logging

Hardware modularity

The wide range of control modules and accessory modules allows you to create a cost effective solution that matches your exact needs.

- Extension modules for extra input and output
- Interoperability between units, e.g. chillers in lead/lag set-up
- One display device can act as service interface for any unit
- Compliance with 3rd party screen solutions, e.g. large touch screen

Full control of peripherals

Open protocols provide all the control designers need and support integration via MODBUS as well as CANbus, which features:

- Fast communication – up to 1 Mbit on 30 m (100 ft) cable length
- Highly scalable, up to 127 networks with up to 100 nodes each

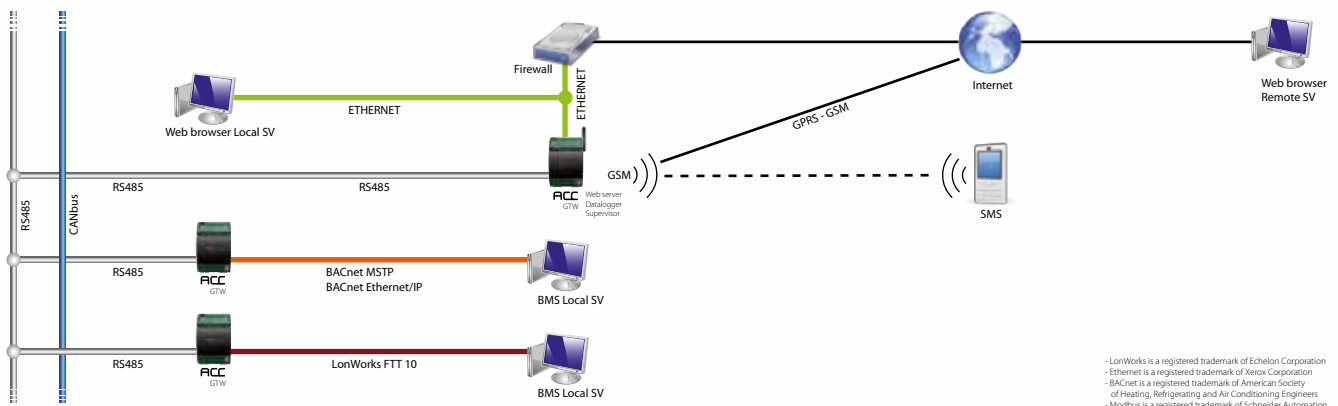

LonWorks is a registered trademark of Echelon Corporation
 Ethernet is a registered trademark of Xerox Corporation
 BACnet is a registered trademark of American Society of Heating, Refrigerating and Air Conditioning Engineers
 Modbus is a registered trademark of Schneider Automation



	LCX06C	MCX06C	MCX06D	MCX061V	MCX08M	MCX15B	MCX20B
ANALOG INPUTS							
NTC 0/1 V, 0/5 V, selectable via software		2	2		4	4	6
NTC, Pt1000, 0/1V, 0/5V, 0/10V, ON/OFF, 0/20mA, 4/20mA, selectable via software	2	2	2	3	4	6	10
NTC, Pt1000, 0/1V, 0/5V, 0/10V, ON/OFF, selectable via software	2						
NTC, 0/1V, 0/5V, 0/10V, ON/OFF, 0/20mA, 4/20mA, selectable via software				2			
Superheat S1: 0/1V, 0/5V, 0/10V, ON/OFF, 0/20m A, 4/20m A, selectable via software				1			
Superheat: S2: PT1000, 0/1V, 0/5V, 0/10V, ON/OFF, selectable via software				1			
Max number	4	4	4	7	8	10	16
DIGITAL INPUTS							
24V optoisolated						18	22
230Vac optoisolated						4	4
Voltage free contact	6	6	8	8	8		
Max number	6	6	8	8	8	18	22
ANALOG OUTPUTS							
0/10Vdc				2			
0/10Vdc optoisolated					2	4	6
0/10Vdc, PWM, PPM selectable via software	2	1	2	1			
PWM, PPM cutting phase		1	1		2	2	
Max number	2	2	3	3	4	6	6
DIGITAL OUTPUTS							
SPST relay 5A	6	6	5	6			
SPST relay 8A					2	9	13
SPDT relay 8A			1		4	4	4
SPST relay 16A					2		2
SPDT relay 16A						2	1
SSR 24Vac/230Vac (optional)			1		2	4	4
Max number	6	6	6	6	8	15	20
POWER SUPPLY							
20/60Vdc - 24Vac	•	•	•	◦	◦	◦	◦
110-230Vac – 50/60Hz				◦	◦	◦	◦
Isolated power supply	•	•	•	•	•	•	•
OTHERS							
Connection for programming key	•	•	•	•	•	•	•
Connection for remote display and keyboard		•	•	•	•	•	•
Buzzer			•	•	•	•	•
CANbus		•	•	•	•	•	•
RTC clock	◦	◦	◦	•	•	•	•
Modbus RS485 serial interface (optional)	1 not isolated	1 not isolated	1	2	1	2	2
Ethernet/ Web server				◦			
Memory card slot				•			
Dimensions	33x75mm	33x75mm	4DIN	8DIN	8DIN	16DIN	16DIN
Mounting	Panel	Panel	DIN rail	DIN rail	DIN rail	DIN rail	DIN rail
• Available for all models ◦ Available for some models							

Danfoss air conditioning offers

A comprehensive range of air conditioning products

Air conditioning compressors, mechanical and electronic components and sub-systems.

Experience

Danfoss has a record of more than 75 years success as a supplier to the air conditioning industry.

Application expertise

A global team of engineers dedicated to support our air conditioning customers' business goals.

In our ARI-certified laboratories, the value and effects of Danfoss innovations are proven daily.



Unit Controller



Cartridge controls



Superheat controller



Electronically controlled expansion valve



Performer® Scroll Compressor



Thermostatic expansion valve



Heat exchanger



4-way reversing valve



Performer®



Sight glasses



Ball valves



Eliminator® Filter driers