

Data sheet

Seated valve for steam (PN 25) VFS 2 – Two way valve, flange

Description



VFS 2 valve is a range of 2 port flanged valve for chilled water, LPHW, MPHw, HPHW (low, medium or high pressure hot water) and steam applications.

The valve is designed to be combined with following actuators:

- DN 15-50 AMV(E) 25 (SU/SD), AMV(E) 35, AMV(E) 56 (with clutch "On request")
- DN 65-100 AMV(E) 55, AMV(E) 56, AMV(E) 85, AMV(E) 86, AMV (E) 65x

Features:

- Logarithmic characteristic
- Rangeability R= >100:1 by DN 20-100
- Suitable for steam applications

Main data:

- DN 15-100
- k_{vs} 0.4-145 m³/h
- PN 25
- Down to close
- Medium:
 - Circulation water/glycolic water up to 50 % / steam (max. Δp = 6 bar)
- Temperature:
 - 2 (-10¹⁾) ... 200 °C

¹⁾ At temperatures from -10 °C up to +2 °C use stem heater

- Logarithmic characteristic
- Flange PN 25 connections
- Compliance with Pressure Equipment Directive 2014/68/EU.

Ordering

Example:
Two way valve, DN 15, k_{vs} 1.6, PN 25, T_{max} 200 °C, flange connection

- 1x VFS 2 DN 15 valve
Code No.: **065B1513**

Two way valve VFS 2

DN	k_{vs} (m ³ /h)	PN	T_{max} (°C)	Code No.
15	0.4	25	200	065B1510
	0.63			065B1511
	1.0			065B1512
	1.6			065B1513
	2.5			065B1514
	4.0			065B1515
20	6.3			065B1520
25	10			065B1525
32	16			065B1532
40	25			065B1540
50	40			065B1550
65	63			065B3365
80	100	065B3380		
100	145	065B3400		

Spare parts – stuffing box

DN	Description	Code No.
15	Four PTFE rings Seal for valve cover Gland ring Washer Instructions	065B0001
20		
25		
32		
40		
50		
65	Three PTFE rings Gland ring Instructions	065B0006
80		
100		

Accessories

Type	Code No.
Stem heater 24 V AC/DC (AMV(E) 25, 35 and VFS 2 valves DN 15-50)	065B2171
Stem heater 24 V AC/DC (AMV(E) 56 and VFS 2 valves DN 15-50)	065Z7020
Stem heater 24 V AC/DC (AMV(E) 85, 86 and VFS 2 valves DN 65-100)	065Z7021
Stem heater 24 V AC/DC (AMV(E) 55, 56, 655, 658, 659 and VFS 2 valves DN 65-100)	065Z7022
Adapter AMV(E) 25 (SU/SD), AMV(E) 35 and VFS 2 DN 15-50 (for media temperatures over 150 °C)	065Z7548
Clutch (AMV(E) 56 and VFS 2 valves DN 15-50)	On request

Technical data

Nominal diameter	DN	15							20	25	32	40	50	65	80	100
k_{vs} value	m ³ /h	0.4	0.63	1.0	1.6	2.5	4.0	6.3	10	16	25	40	63	100	145	
Stroke	mm	15											40			
Rangeability		> 30:1			> 50:1				> 100:1							
Control characteristic		Logarithmic														
Cavitation factor z		0.5							0.5	0.5	0.5	0.5	0.5	0.4	0.3	0.3
Leakage acc. to standard IEC 534		< 0.05 % of k_{vs}														
Nominal pressure	PN	25														
Medium		Circulation water/glycolic water up to 50 % /steam (max. $\Delta p = 6$ bar)														
Medium pH		Min. 7, max. 10														
Medium temperature	°C	2 (-10 ¹⁾) ... 200														
Connections		Flange ISO 7005-2														
Materials																
Body and cover		Ductile iron EN-GJS-400-18-LT (GGG 40.3)												Ductile iron EN-GJS-400-15 (GGG 40)		
Cone, seat and spindle		Stainless steel														
Gland seal		Replaceable PTFE rings														

¹⁾ At temperatures from -10 °C ... +2 °C use stem heater .

Pressure temperature diagram

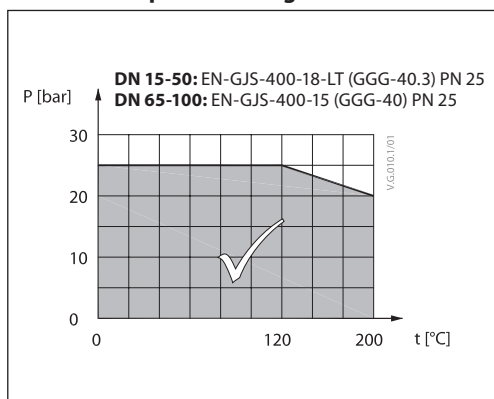

Valve characteristics-logarithmic

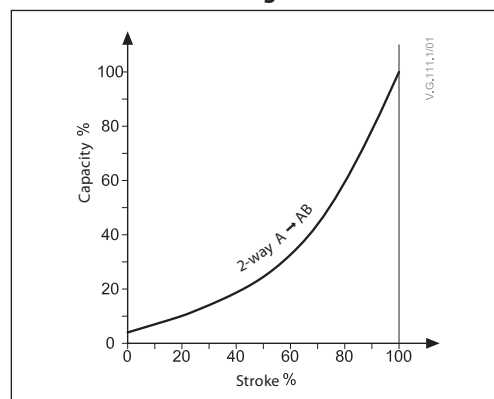

Max. closing pressure¹⁾ and recommended Δp ²⁾

Valve		Actuator					
DN	Stroke (mm)	AMV(E) 25 [AMV(E) 25 SU/SD] ³⁾	AMV(E) 35	AMV(E) 55	AMV(E) 56	AMV(E) 85, 86	AMV(E) 65x
		max. closing pressure ¹⁾ (bar)					
15	15	25 [22 ³⁾]	25	-	25 ⁴⁾	-	-
15 (k_{vs} 4.0)		25 [16 ³⁾]	20	-	25 ⁴⁾	-	-
20		25 [10 ³⁾]	13	-	25 ⁴⁾	-	-
25		16 [5 ³⁾]	8	-	21 ⁴⁾	-	-
32		9 [2.5 ³⁾]	5	-	12 ⁴⁾	-	-
40		6 [2 ³⁾]	3	-	8 ⁴⁾	-	-
50		3 [0.5 ³⁾]	2	-	5 ⁴⁾	-	-
65	40	-	-	4.5	3	13	4.5
80		-	-	3	2	8	3
100		-	-	1.5	1	5	1.5

Note:

- ¹⁾ Max. Δp is the physical limit of differential pressure the valve will close against. Max. Δp for stem application is 6 bar.
- ²⁾ The recommended Δp is based on the generation of noise, plug erosion etc. Max. recommended Δp is 4 bar. If max. closing pressure is smaller than 4 bar than the recommended Δp is the same as closing Δp .
- ³⁾ Values in parentheses [] are based on the force of the actuator AMV(E) 25 SU/SD only.
- ⁴⁾ With stem connector (On request)

Installation

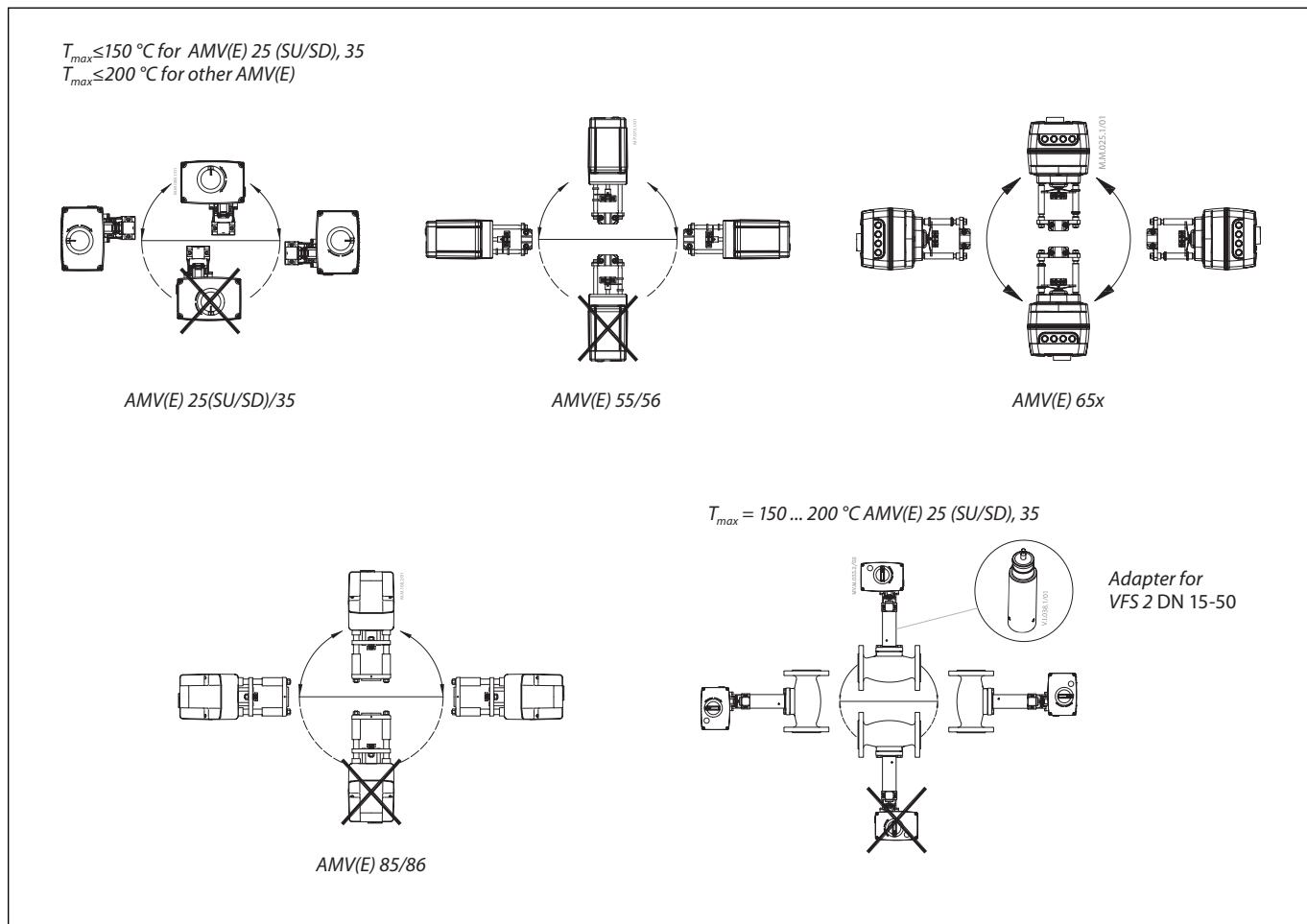

Valve mounting

Before mounting the valve be sure that the pipes are clean and free from abrasion.

It is essential that the pipes are lined up squarely with the valve at each connection and that they are free from vibrations.

Install the motorized control valves with the actuator in a vertical or horizontal position in accordance to recommendations described in Installation above.
 Note that the actuator may be rotated up to 360° with respect to the valve body by loosening the retaining fixture. After this operation retighten.

Leave sufficient clearance to facilitate the dismantling of the actuator from the valve body for maintenance purposes.

Note that the actuator may be rotated up to 360° with respect to the valve body by loosening the retaining fixture. After this operation retighten.

Always install the valve with the arrow on the body in the same direction as the flow. In order to avoid turbulence, which will affect the measuring accuracy, it is recommended to have a straight length of pipe up and down stream from the valve as shown (D - diameter of pipe).

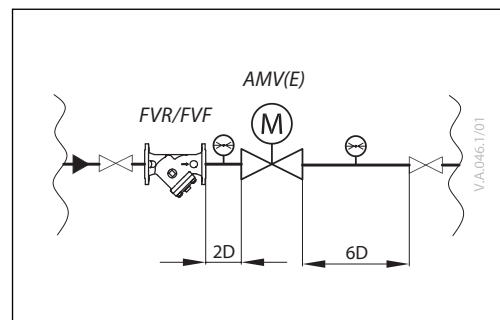

Note: Install a strainer upstream of the valve (e.g. Danfoss FVR/FVF)

Disposal

The valve must be dismantled and the elements sorted into various material groups before disposal.

Control valve sizing diagram for fluids

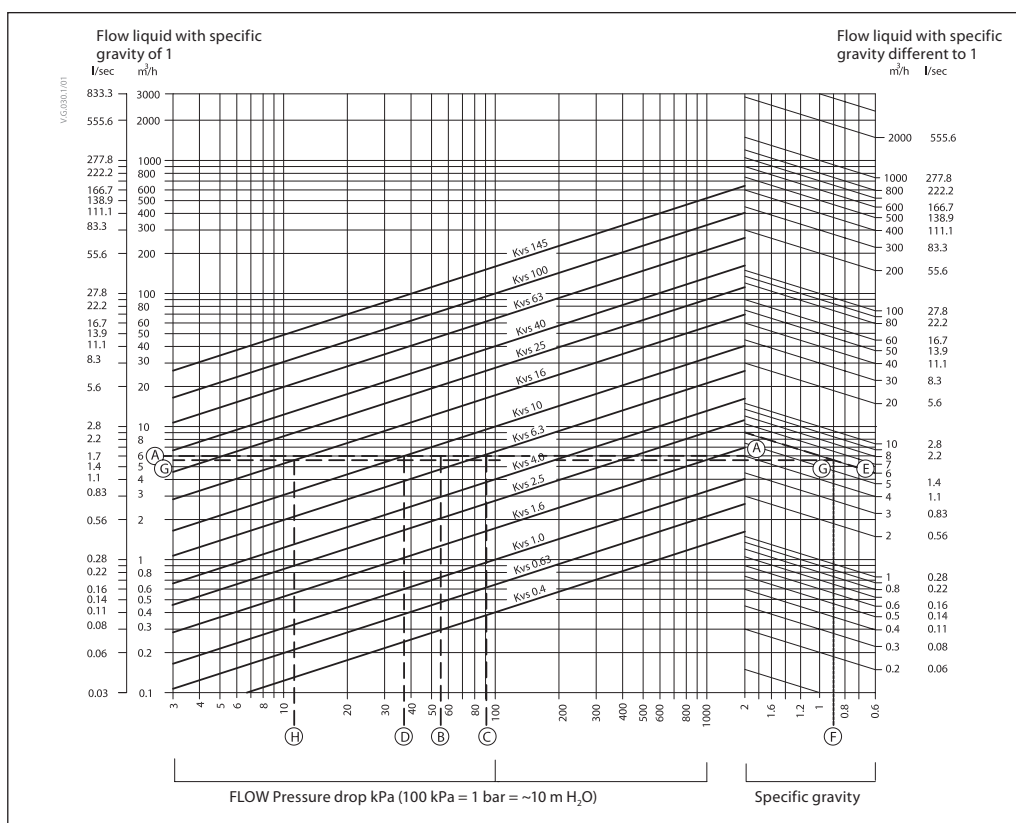

Examples:

1 For fluids with specific gravity of 1 (e.g. water)

Design data:

Flow rate: 6 m³/h
System pressure drop: 55 kPa

Locate the horizontal line representing a flow rate of 6 m³/h (line A-A). The valve authority is given by the equation:

$$\text{Valve authority, } a = \frac{\Delta p_1}{\Delta p_1 + \Delta p_2}$$

Where:

Δp_1 = pressure drop across the fully open valve
 Δp_2 = pressure drop across the rest of the circuit with a full open valve

The ideal valve would give a pressure drop equal to the system pressure drop (i.e. an authority of 0.5):

$$\text{If } \Delta p_1 = \Delta p_2$$

$$a = \frac{\Delta p_1}{2 \times \Delta p_1} = 0.5$$

In this example an authority of 0.5 would be given by a valve having a pressure drop of 55 kPa at that flow rate (point B). The intersection of line A-A with a vertical line drawn from B lies between two diagonal lines; this means that no ideally-sized valve is available. The intersection of line A-A with the diagonal lines gives the pressure drops stated by real, rather than ideal, valves. In this case, a valve with k_{VS} 6.3 would give a pressure drop of 90.7 kPa (point C):

$$\text{hence valve authority} = \frac{90.7}{90.7 + 55} = 0.62$$

The largest valve, with k_{VS} 10, would give a pressure drop of 36 kPa (point D):

$$\text{hence valve authority} = \frac{36}{36 + 55} = 0.395$$

Generally, the smaller valve would be selected (resulting in a valve authority higher than 0.5 and therefore improved control). However, this will increase the total pressure and should be checked by the system designer for compatibility with available pump heads, etc. The ideal authority is 0.5 with a preferred range of between 0.4 and 0.7.

2 For fluids with specific gravity (S.G.) different from 1

Design data:

Flow rate: 6 m³/h of fluid, S.G. 0.9
System pressure drop: 10 kPa

For this example, the left hand axis of the diagram must be ignored. Starting from the right hand axis, the flow rate of 6 m³/h is located (point E). The intersection of the diagonal line from point E with a vertical line from S.G. = 0.9 (point F) gives the starting point for the effective flow rate line G-G. The process then continues as for Example 1, so 10 kPa intersects G-G nearest to the k_{VS} 16 diagonal. The intersection of G-G with k_{VS} 16 gives a valve pressure drop of 12.7 kPa (point H).

Control valve sizing diagram for steam

Max. Δp in low pressure steam application variance from 0.5 bar to 6 bar (see page 2)

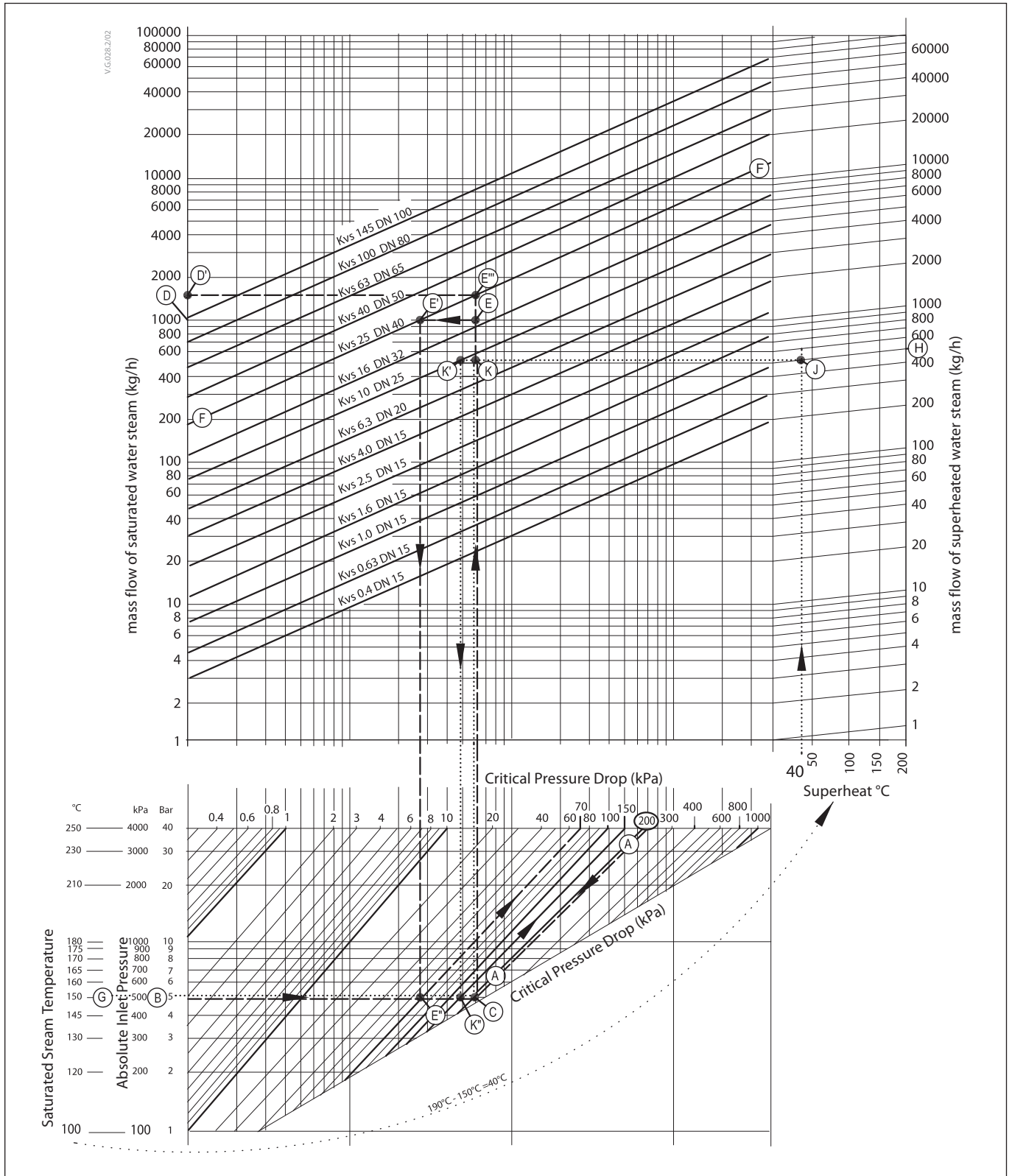

Steam valve sizing is based on 40 % of the absolute steam pressure (immediately upstream of the valve), being dropped across the valve when fully open. At this condition the steam is travelling at or close to its critical velocity

(approx. 300 m/s) and throttling will occur over the full valve stroke. If the steam is travelling slower than this then the first part of the valve stroke will merely increase the velocity of the steam without reducing the volumetric flow.

Control valve sizing diagram for steam

(continued)

1 For saturated steam

Design data:

Flow rate: 1000 kg/h

Absolute inlet pressure: 5 bar (500 kPa)

- follow dashed line -

The absolute inlet pressure is 500 kPa. 40% of this is 200 kPa.

Locate the diagonal line corresponding to the pressure drop of 200 kPa (line A-A).

Read the absolute inlet pressure on the lower left hand scale (point B), and draw a horizontal line across until it meets the pressure drop diagonal (A-A) at point C.

From this point extend a vertical line upwards until it meets the horizontal line representing the steam flow of 1000 kg/h from point D. The intersection of this is point E.

The nearest diagonal k_{vs} line above this is line F-F with a k_{vs} of 25 (point E'). If the ideal valve size is not available the next largest size should be selected to ensure design flow.

The pressure drop through valve at the flow rate is found by the intersection of the 1000 kg/h line with F-F (point E') and dropping a vertical; this actually hits the horizontal line for 500 kPa (point E'') inlet pressure at a pressure drop diagonal of 70 kPa. This is only 14 % of the inlet pressure and the control quality will not be good until the valve has partially closed. As with all steam valves this compromise is necessary since the next smaller valve would not pass the required flow (maximum flow would have been about 600 kg/h).

The maximum flow for same inlet pressure is found by extending the vertical line (C-E) through point E until it crosses the k_{vs} 25 line F-F (point E''') and reading off the flow (1700 kg/h).

2 For superheated steam

Design data:

Flow rate: 500 kg/h

Absolute inlet pressure: 5 bar (500 kPa)

Steam temperature: 190 °C

The procedure for superheated steam is much the same as for saturated steam, but uses a different flow scale which slightly elevates the readings according to the degree of superheat.

- follow dotted line -

As before, the diagonal pressure drop line A-A is located as before for 40 % of 500 (200 kg/h). The horizontal inlet pressure line through point B is now extended to the left to read off the corresponding saturated steam temperature at point G (150 °C). The difference between the saturated steam temperature and the superheated steam temperature is 190 °C - 150 °C = 40 °C.

The superheated steam flow is found on the upper right hand scale, point H, and the diagonal line is followed down from here until it meets a vertical line from the steam temperature elevation (40 °C) at point J.

As before, the horizontal line through point B is drawn to cut line A-A at point C and the point where the vertical line from this point meets the horizontal line from point J is the operating point (point K). This horizontal line, J-K, is the corrected flow line. The nearest diagonal line above this is for k_{vs} 10 (point K'). A vertical line dropped from the intersection of J-K with the 10 k_{vs} line intersects the 500 kPa inlet pressure line (point K'') at a pressure drop diagonal of about 150 kPa. This is about 30% of the inlet pressure which will give reasonable control quality (compared to recommended ratio of 40%).

Dimensions

