

Data sheet

Differential pressure controller (PN 16)

AVLP - return mounting, adjustable setting

Description



AVPL is a self-acting differential pressure controller primarily for use in district heating systems. The controller closes on rising differential pressure.

The controller has a control valve and an actuator with one control diaphragm.

It can be used on primary side of house substations for smaller systems such as one and two-family houses.

The controller could be used to control the differential pressure across radiator systems and similar systems to keep a constant differential pressure even with a variable system resistance k_{vs} and/or supply pressure Δp_0 .

Main data:

- DN 15
- k_{vs} 1.0, 1.6 m³/h
- PN 16
- Setting range: 0.05-0.25 bar (factory setting 0.1 bar)
- Temperature:
 - Circulation water / glycolic water up to 30%: 2 ... 120 °C
- Connections:
 - Ext thread (weld-on and thread tailpieces)

Ordering

Example:
Differential pressure controller, return mounting, DN 15, k_{vs} 1.0, PN 16, setting range 0.05 - 0.25 bar, t_{max} 120 °C, ext. thread

- 1x AVPL DN 15 controller
Code No: **003L5030**

Option:

- 1x Weld-on tailpieces
Code No: **003H6908**

AVPL Controller

Picture	DN (mm)	k_{vs} (m ³ /h)	Connection		Δp setting range (bar)	Code No. *
	15	1.0	Ext. thread acc. to ISO 228/1	G 3/4 A	0.05-0.25	003L5030
		1.6				003L5031

* Controller incl. impulse tube set AH (1.5 m at k_{vs} 1.0 and 2.5 m at k_{vs} 1.6) and nipple G 1/16 - R 3/8 for impulse tube connection to pipe

Accessories

Picture	Type designation	DN	Connection	Code No.
	Weld-on tailpieces	15	-	003H6908
	External thread tailpieces		Conical ext. thread acc. to EN 10226-1	R 1/2
	Impulse tube set AH	Description: - 1x copper tube \varnothing 3 x 1 mm - 2x fitting for imp. tube connection to actuator and pipe G 1/16	1.5 m	003L3561
			2.5 m	003L5043
			5 m	003L3562
	Fitting for impulse tube connection to pipe		G 1/16 - R 3/8	003L5042
			G 1/16 - R 1/4	003L8151
	EPP insulation box ¹⁾			003L8170
	10 EPDM o-rings for impulse tube			003L8175

¹⁾ The material for the insulation box is approved according to the fire hazard classification B2, DIN 4102.

Technical data

Nominal diameter	DN	15	
k_{vs} value	m^3/h	1.0	1.6
Cavitation factor z		0.5	
Nominal pressure	PN	16	
Max. differential pressure	bar	4.5	
Medium		Circulation water / glycolic water up to 30%	
Medium pH		Min. 7, max. 10	
Medium temperature	°C	2 ... 120	
Connections	valve	External thread	
	tailpieces	Weld-on and external thread	
Materials			
Valve body, etc.		Dezincing free brass CuZn36Pb2As	
Cone, seat, spindle and spring		Stainless steel	
Diaphragm and O-ring		EPDM	
Impulse tube		Copper tube $\varnothing 3 \times 1$ mm	
		Stainless steel tube $\varnothing 0.8 \times 0.2 \times 800$ mm	

Application principles

The controller AVPL could be installed in the return pipeline only.

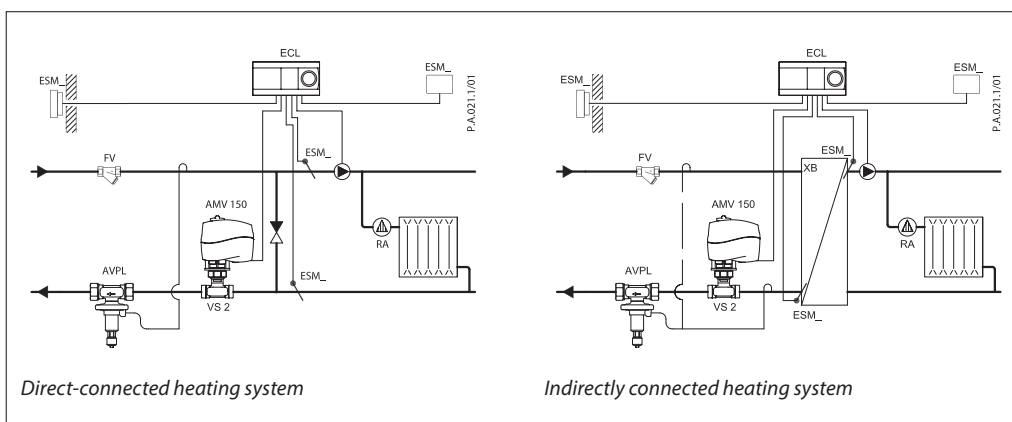

Installation positions

The controllers can be installed in any position.

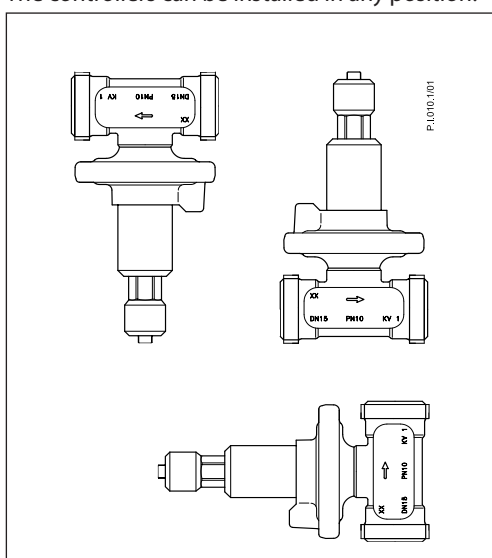

Sizing

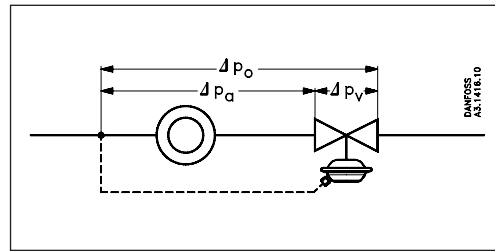

Considering the correlation between the capacity of the system k_{va} , the system flow Q and the differential pressure Δp_a , the controller setting Δp_i is determined by:

$$\Delta p_i = \Delta p_a = (Q/k_{va})^2$$

Based on the stated differential pressure of the district heating Δp_o and the calculated differential pressure of the system Δp_a , the differential pressure across the controller valve is expressed as:

$$\Delta p_v = \Delta p_o - \Delta p_a$$

Finally, a check is required to ensure that the actual capacity of the controller k_{vv} is smaller than its max. capacity k_{vs}

$$k_{vv} = Q / \sqrt{\Delta p_v} \leq k_{vs}$$

Example:

A heating system with a number of parallel hot surfaces.
 Required flow:
 $Q = 0.24 \text{ m}^3/\text{h}$
 Total capacity of the system determined to be $k_{va} = 0.6 \text{ m}^3/\text{h}$.

Calculation of the differential pressure across the system:

$$\Delta p_a = (Q/k_{va})^2 = (0.24/0.6)^2 = 0.16 \text{ bar (16 kPa)}$$

The differential pressure from the district heating is stated to be:

$$\Delta p_o = 0.5 \text{ bar (50 kPa) min}$$

Calculation of the differential pressure across the controller valve:

$$\Delta p_v = \Delta p_o - \Delta p_a = 0.5 \text{ bar} - 0.16 \text{ bar} = 0.34 \text{ bar (34 kPa)}$$

In this example the capacity of the controller valve is:

$$k_{vv} = Q/\sqrt{\Delta p_v} = 0.24/\sqrt{0.34} = 0.412 \text{ m}^3/\text{h}$$

which is less than the max. capacity of the controller $= k_{vs} = 1.0 \text{ m}^3/\text{h}$.

Design

1. Spindle for differential pressure setting
2. Bushing
3. Actuator
4. Control diaphragm
5. Setting spring for diff. pressure control
6. Connection for impulse tube
7. O-ring
8. Pressure relieved valve cone
9. Seat
10. Valve body

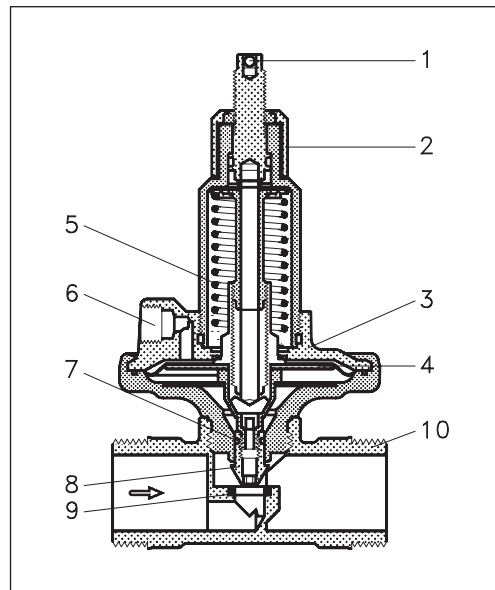

Function

AVPL is a proportional controller which operates according to the following principle: The degree of opening of the control valve / k_v value is proportional to the deviation between the controlled and set differential pressure, $\Delta p_a - \Delta p_s$. Thus the resistance/ k_v value is adjusted to the actual differential pressure Δp_v and accordingly, the flow Q is adjusted so that the desired differential pressure Δp_a is obtained across the actual resistance k_{va} in the system.

Differential pressure across the system

$$\Delta p_a = \left(\frac{Q}{k_{va}} \right)^2$$

Differential pressure across the controller

$$\Delta p_v = \left(\frac{Q}{k_w} \right)^2$$

Differential pressure from the district heating

$$\Delta p_o = \Delta p_a + \Delta p_v$$

Rewritten the flow can be expressed as

$$= \sqrt{\frac{\Delta p_o}{1/(k_{va})^2 + 1/(k_w)^2}}$$

The max. flow is limited by the min. differential pressure of the district heating $\Delta p_{o_{min}}$, the max. capacity of the system $k_{va_{max}}$ and of the max. capacity of the controller k_{vs} .

Max. system flow:

$$Q_{max} = \sqrt{\frac{\Delta p_{o_{min}}}{1/(k_{va_{max}})^2 + 1/(k_{vs})^2}}$$

Settings

AVPL can be set to any differential pressure within the range 5 kPa to 25 kPa (0.05 bar to 0.25 bar). The factory pre-setting of the AVPL is 10 kPa (0.1 bar), 1 kPa for each turn.

As mentioned above, the proportional effect depends on the correlation between the controller valve's degree of opening and the deviation between the controlled and set differential pressure. Furthermore, the deviation depends on the actual differential pressure across the control valve and the actual control setting.

The chosen deviation is large enough to ensure a stable control and small enough to keep the controlled differential pressure within acceptable limits.

The controller is designed in such a way that the controlled and the set differential pressures are equal when the flow is about 250 l/h for AVPL 1.0 and 400 l/h for AVPL 1.6 at nominal differential pressure 50 kPa (Δp_s). At min. and max. flow the controlled differential pressure deviates from the set pressure with $\pm 1 \dots 3$ kPa, depending on the actual differential pressure and setting.

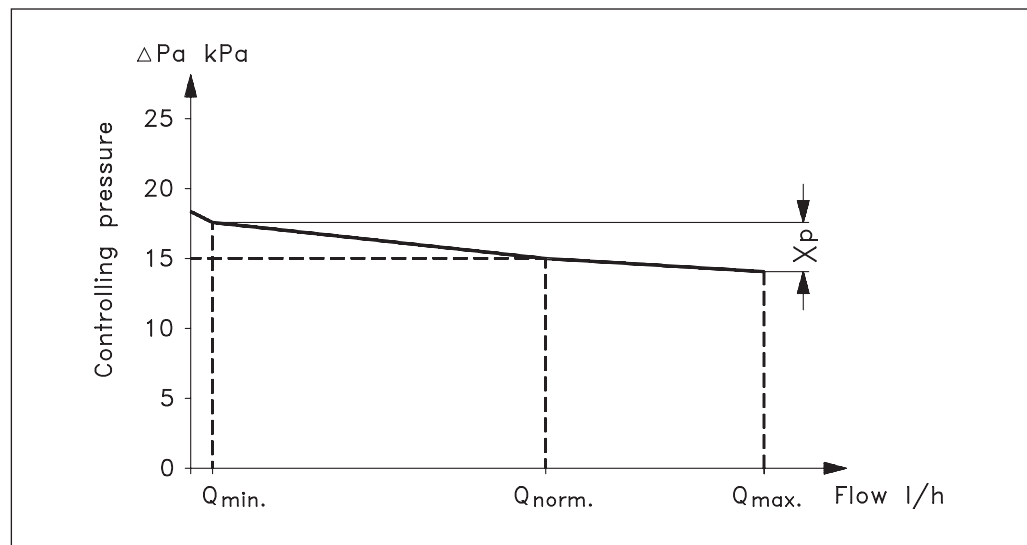

Dimensions

