

Data sheet

# Differential pressure and flow controller (PN 25)

**AVPQ** – return mounting, adjustable setting

**AVPQ 4** – flow mounting, adjustable setting

Description

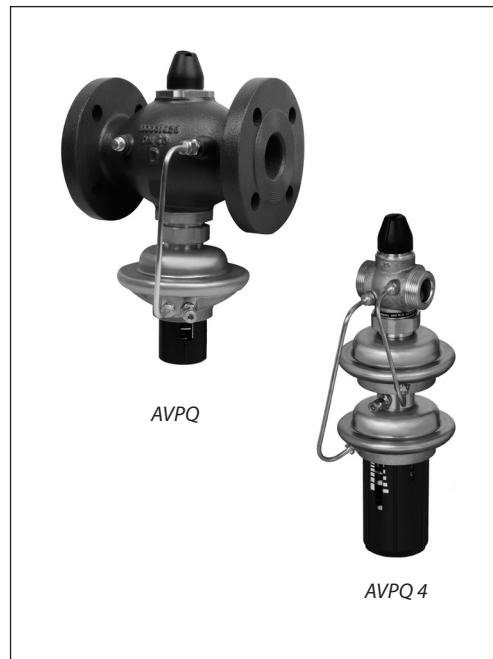

AVPQ(4) is a self-acting differential pressure and flow controller primarily for use in district heating systems. The controller closes on rising differential pressure or when set max. flow is exceeded.

The controller has a control valve with adjustable flow restrictor, an actuator with two control diaphragms and handle for differential pressure setting.

**Main data:**

- DN 15-50
- $k_{vs}$  0.4-25 m<sup>3</sup>/h
- Flow range: 0.015-15 m<sup>3</sup>/h
- PN 25
- Setting range: 0.2-1.0 bar/0.3-2.0 bar
- Flow restrictor  $\Delta p_r$ : 0.2 bar
- Temperature:
  - Circ. water / glycolic water up to 30% :
  - 2 ... 150 °C
- Connections:
  - Ext. thread (weld-on, ext. thread and flange tailpieces)
  - Flange

Ordering

*Example:*  
Differential pressure and flow controller; return mounting;  
DN 15;  $k_{vs}$  1.6; PN 25;  
setting range 0.2-1.0 bar;  
 $T_{max}$  150 °C; ext. thread

- 1x AVPQ DN 15 controller  
Code No: **003H6531**
- 1x Impulse tube set AV, R 1/8  
Code No: **003H6852**

*Option:*

- 1x Weld-on tailpieces  
Code No: **003H6908**

The controller will be delivered completely assembled, inclusive impulse tube(s) between valve and actuator. External impulse tube (AV) must be ordered separately.

AVPQ Controller (return mounting)

Picture	DN (mm)	$k_{vs}$ (m <sup>3</sup> /h)	Connection	$\Delta p$ setting range (bar)	Code No.	$\Delta p$ setting range (bar)	Code No.
	15	0.4	Cylindr. ext. thread acc. to ISO 228/1	G 3/4 A	003H6918	0.2-1.0	0.3-2.0
		1.0			003H6919		
		1.6			003H6531		
		2.5			003H6532		
		4.0			003H6533		
	20	6.3	G 1 A	003H6534			
	25	8.0	G 1 1/4 A	003H6535			
	32	12.5	G 1 3/4 A	003H6536			
	40	16	G 2 A	003H6537			
	50	20	G 2 1/2 A	003H6538			
	32	12.5	Flanges PN 25, acc. to EN 1092-2		003H6563		003H6566
	40	20			003H6564		003H6567
	50	25			003H6565		003H6568

Ordering (continuous)

AVPQ 4 Controller (flow mounting)

Picture	DN (mm)	$k_{vs}$ (m <sup>3</sup> /h)	Connection		$\Delta p$ setting range (bar)	Code No.	$\Delta p$ setting range (bar)	Code No.
	15	0.4	Cylindr. ext. thread acc. to ISO 228/1	G 3/4 A	0.2-1.0	003H6922	0.3-2.0	003H6924
		1.0				003H6923		003H6925
		1.6				003H6547		003H6555
		2.5				003H6548		003H6556
		4.0				003H6549		003H6557
	20	6.3		G 1 A		003H6550		003H6558
	25	8.0		G 1 1/4 A		003H6551		003H6559
	32	12.5		G 1 3/4 A		003H6552		003H6560
	40	16		G 2 A		003H6553		003H6561
	50	20		G 2 1/2 A		003H6554		003H6562
	32	12.5	Flanges PN 25, acc. to EN 1092-2			003H6569		003H6572
	40	20				003H6570		003H6573
	50	25				003H6571		003H6574

Accessories

Picture	Type designation	DN	Connection	Code No.
	Weld-on tailpieces	15	-	003H6908
		20		003H6909
		25		003H6910
		32		003H6911
		40		003H6912
		50		003H6913
	External thread tailpieces	15	Conical ext. thread acc. to EN 10226-1	R 1/2 003H6902
		20		R 3/4 003H6903
		25		R 1 003H6904
		32		R 1 1/4 003H6905
		40		R 1 1/2 065B2004
		50		R 2 065B2005
	Flange tailpieces	15	Flanges PN 25, acc. to EN 1092-2	003H6915
		20		003H6916
		25		003H6917
	Impulse tube set AV	Description: - 1x copper tube $\varnothing 6 \times 1 \times 1500$ mm - 1x compression fitting 1) for imp. tube connection to pipe $\varnothing 6 \times 1$ mm		R 1/8 003H6852
				R 3/8 003H6853
				R 1/2 003H6854
	1) 10 compression fittings for imp. tube connection to pipe, $\varnothing 6 \times 1$ mm R 1/8			003H6857
	1) 10 compression fittings for imp. tube connection to pipe, $\varnothing 6 \times 1$ mm R 3/8			003H6858
	1) 10 compression fittings for imp. tube connection to pipe, $\varnothing 6 \times 1$ mm R 1/2			003H6859
	1) 10 compression fittings for imp. tube connection to actuator, $\varnothing 6 \times 1$ mm G 1/8			003H6931
	Shut off valve $\varnothing 6$ mm			003H0276

<sup>1)</sup> Compression fitting consists of a nipple, compression ring and nut.

Ordering (continuous)

Service kits

Picture	Type designation	DN	k <sub>vs</sub> (m <sup>3</sup> /h)	Code No.
	Valve insert	15	0.4	003H6861
			1.0	003H6862
			1.6	003H6863
			2.5	003H6864
			4.0	003H6865
		20	6.3	003H6866
		25	8.0	003H6867
		32 / 40 / 50	12.5 / 16 / 20 / 25	003H6868

Picture	Type designation	Δp setting range (bar)	Code No.	
			AVPQ	AVPQ 4
	Actuator with adjustable handle	0.2-1.0	003H6833	003H6838
		0.3-2.0	003H6850	003H6851

Technical data

Valve

Nominal diameter		DN	15				20	25	32	40	50		
k <sub>vs</sub> value		m <sup>3</sup> /h	0.4	1.0	1.6	2.5	4.0	6.3	8.0	12.5	16/20 <sup>4)</sup>	20/25 <sup>4)</sup>	
Range of max. flow setting	Δp <sub>b</sub> <sup>1)</sup> = 0.2 bar		from	0.015	0.02	0.03	0.07	0.07	0.16	0.2	0.4	0.8	0.8
			to	0.18	0.4	0.86	1.4	2.2	3.0	3.5	8.0	10	12
			or to <sup>3)</sup>	-	-	0.9	1.6	2.4	3.5	4.5	10	12	15
Cavitation factor z			≥ 0.6					≥ 0.55		≥ 0.5			
Leakage acc. to standard IEC 534		% of k <sub>vs</sub>	≤ 0.02						≤ 0.05				
Nominal pressure		PN	25										
Min. differential pressure		bar	see remark <sup>2)</sup>										
Max. differential pressure			20						16				
Medium		Circulation water / glycolic water up to 30%											
Medium pH		Min. 7, max. 10											
Medium temperature		°C	2 ... 150										
Connections	valve	External thread						Ext. thread and flange					
	tailpieces	Weld-on and external thread											
		Flange						-					
<b>Materials</b>													
Valve body	thread	Red bronze CuSn5ZnPb (Rg5)								Ductile iron EN-GJS-400-18-LT (GGG 40.3)			
	flange	-											
Valve seat		Stainless steel, mat. No. 1.4571											
Valve cone		Dezincing free brass CuZn36Pb2As											
Sealing		EPDM											
Pressure relieve system		Piston											

<sup>1)</sup> Δp<sub>b</sub> - differential pressure over flow restrictor

<sup>2)</sup> Depends on the flow rate and valve k<sub>vs</sub>; For Q<sub>set</sub> = Q<sub>max</sub> → Δp<sub>min</sub> ≥ 0.5 bar; For Q<sub>set</sub> < Q<sub>max</sub> → Δp<sub>min</sub> =  $\left(\frac{Q}{k_{vs}}\right)^2 + \Delta p_b$

<sup>3)</sup> Higher max flow are achieved at higher differential pressures over AVPQ(4) controller. In general at Δp > 1-1.5 bar

<sup>4)</sup> Flange valve body

Technical data (continuous)

Actuator

Type		AVPQ		AVPQ 4	
Actuator size	cm <sub>2</sub>	54			
Nominal pressure	PN	25			
Flow restrictor diff. pressure, Δpb	bar	0.2			
Diff. pressure setting ranges and spring colours	bar	0.2-1.0	0.3-2.0	0.2-1.0	0.3-2.0
		yellow	red	yellow	red
<b>Materials</b>					
Housing	Upper casing of actuator	Stainless steel, mat. No.1.4301			
	Lower casing of actuator	Dezincing free brass CuZn36Pb2As			
Diaphragm	EPDM				
Impulse tube	Copper tube Ø6 × 1 mm				

Application principles

- Return mounting

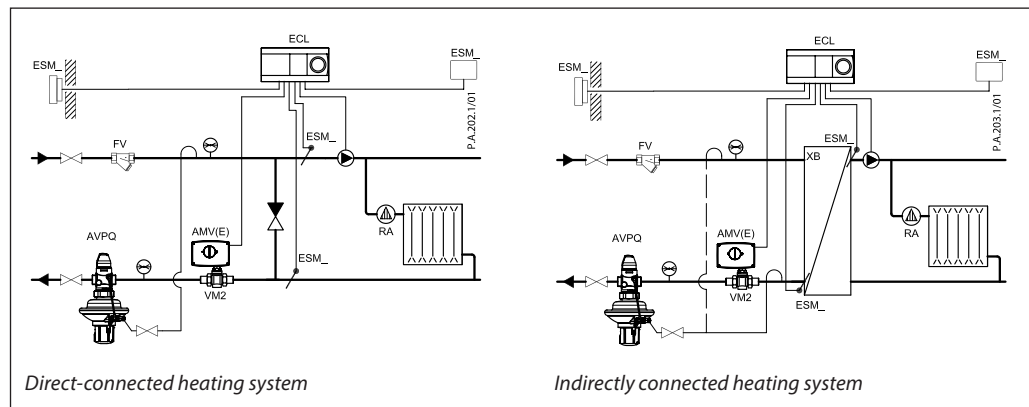

- Flow mounting

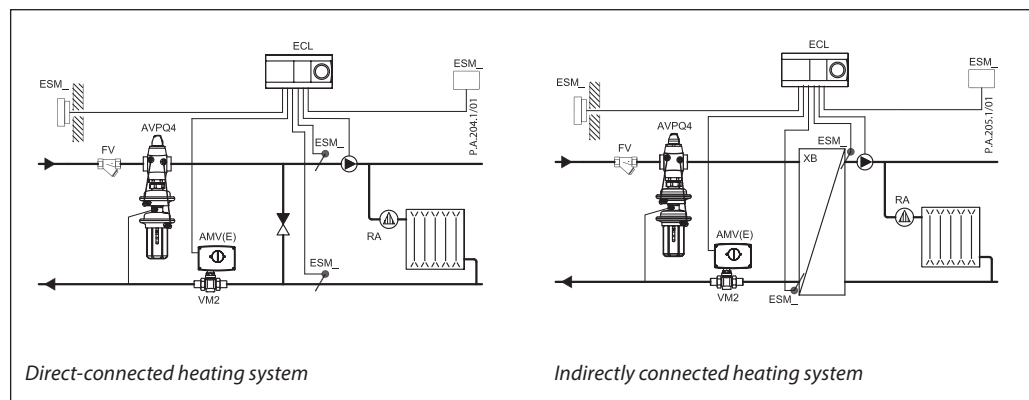

Installation positions

Up to medium temperature of 100 °C the controllers can be installed in any position.

For higher temperatures the controllers have to be installed in horizontal pipes only, with a pressure actuator oriented downwards.

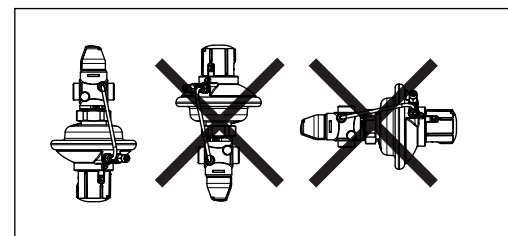
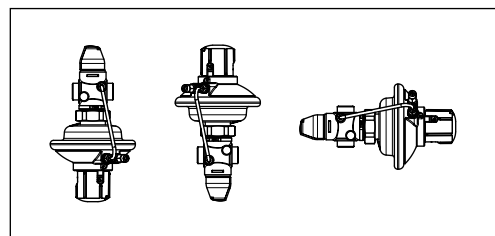

**Pressure temperature diagram**

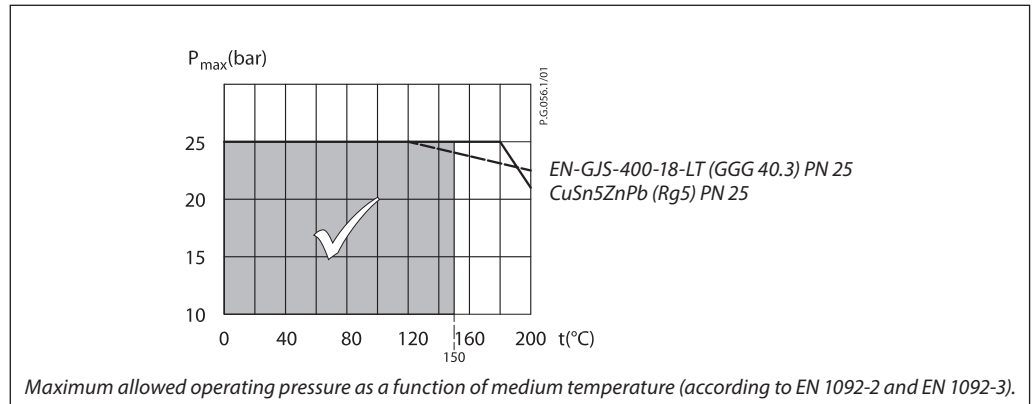

**Flow diagram**

*Sizing and setting diagram*

Relation between actual flow and number of revolutions on flow restrictor. Values given are approximate.

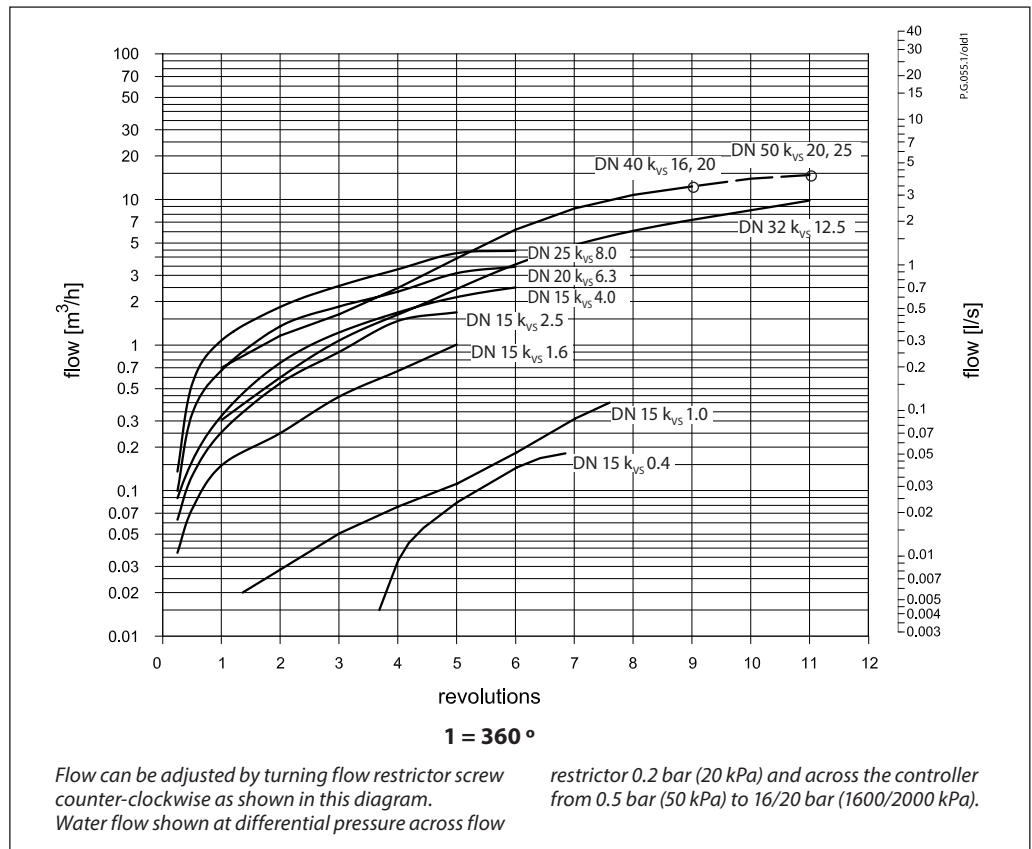

**Remark:**  
Controllers DN 40 and DN 50 have the same curve up to 9 revolutions.

**Note:**  
For max flow setting on the controller diagrams from Instructions should be used.

**Sizing**

- Directly connected heating system

**Example 1**

Motorised control valve (MCV) for mixing circuit in direct-connected heating system requires differential pressure of 0.3 bar (30 kPa) and flow less than 1900 l/h.

The total pressure loss across the controller is:

$$\Delta p_{AVPQ} = \Delta p_{min} - \Delta p_{MCV} = 0.9 - 0.3$$

$$\Delta p_{AVPQ} = 0.6 \text{ bar (60 kPa)}$$

Possible pipe pressure losses in tubes, shut-off fittings, heatmeters, etc. are not included.

$k_v$  value is calculated according to formula:

$$k_v = \frac{Q_{max}}{\sqrt{\Delta p_{AVPQ} - \Delta p_b}} = \frac{1.9}{\sqrt{0.6 - 0.2}}$$

$$k_v = 3.0 \text{ m}^3/\text{h}$$

Given data:

- $Q_{max} = 1.9 \text{ m}^3/\text{h}$  (1900 l/h)
- $\Delta p_{min} = 0.9 \text{ bar}$  (90 kPa)
- $\Delta p_{circuit}^1 = 0.1 \text{ bar}$  (10 kPa)
- $\Delta p_{MCV} = 0.3 \text{ bar}$  (30 kPa) selected
- $\Delta p_b^2 = 0.2 \text{ bar}$  (20 kPa)

Remark:

<sup>1)</sup>  $\Delta p_{circuit}$  corresponds to the required pump pressure in the heating circuit and is not to be considered when sizing the AVPQ(4).

<sup>2)</sup>  $\Delta p_b$  is differential pressure over flow restrictor.

Solution:

The example selects AVPQ(4) DN 15,  $k_{v5}$  value 4.0, with differential pressure setting range 0.2-1.0 bar, flow setting range 0.07-2.4  $\text{m}^3/\text{h}$ .

The differential pressure set value is:

$$\Delta p_{set \text{ value}} = \Delta p_{MCV}$$

$$\Delta p_{set \text{ value}} = 0.3 \text{ bar (30 kPa)}$$

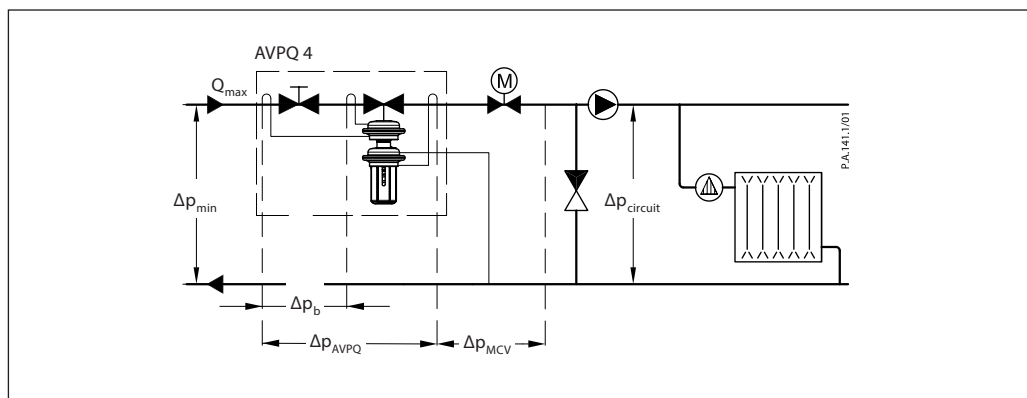
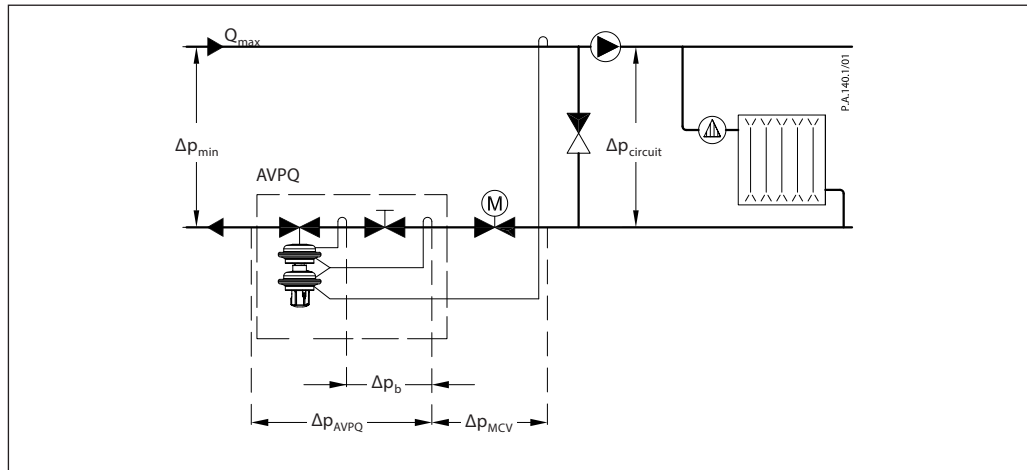

**Sizing** (continuous)

- Indirectly connected heating system

**Example 2**

Motorised control valve (MCV) for indirectly connected heating system requires differential pressure of 0.3 (30 kPa) bar and flow less than 1150 l/h.

*Given data:*

- $Q_{max}$  = 1.15 m<sup>3</sup>/h (1150 l/h)
- $\Delta p_{min}$  = 1.0 bar (100 kPa)
- $\Delta p_{exchanger}$  = 0.05 bar (5 kPa)
- $\Delta p_{MCV}$  = 0.3 bar (30 kPa) selected
- $\Delta p_b^{1)}$  = 0.2 bar (20 kPa)

*Remark:*

<sup>1)</sup>  $\Delta p_b$  is differential pressure over flow restrictor

The differential pressure set value is:

- $\Delta p_{set\ value} = \Delta p_{exchanger} + \Delta p_{MCV}$
- $\Delta p_{set\ value} = 0.05 + 0.3$
- $\Delta p_{set\ value} = 0.35\ bar\ (35\ kPa)$

The total pressure loss across the controller is:

$$\begin{aligned} \Delta p_{AVPQ} &= \Delta p_{min} - \Delta p_{exchanger} - \Delta p_{MCV} \\ \Delta p_{AVPQ} &= 1.0 - 0.05 - 0.3 \\ \Delta p_{AVPQ} &= 0.65\ bar\ (65\ kPa) \end{aligned}$$

Possible pipe pressure losses in tubes, shut-off fittings, heatmeters, etc. are not included.

$k_v$  value is calculated according to formula:

$$k_v = \frac{Q_{max}}{\sqrt{\Delta p_{AVPQ} - \Delta p_b}} = \frac{1.15}{\sqrt{0.65 - 0.2}}$$

$$k_v = 1.7\ m^3/h$$

*Solution:*

The example selects AVPQ(4) DN 15,  $k_{vS}$  value 2.5, with differential pressure setting range 0.2-1.0 bar, flow setting range 0.07-1.6 m<sup>3</sup>/h.

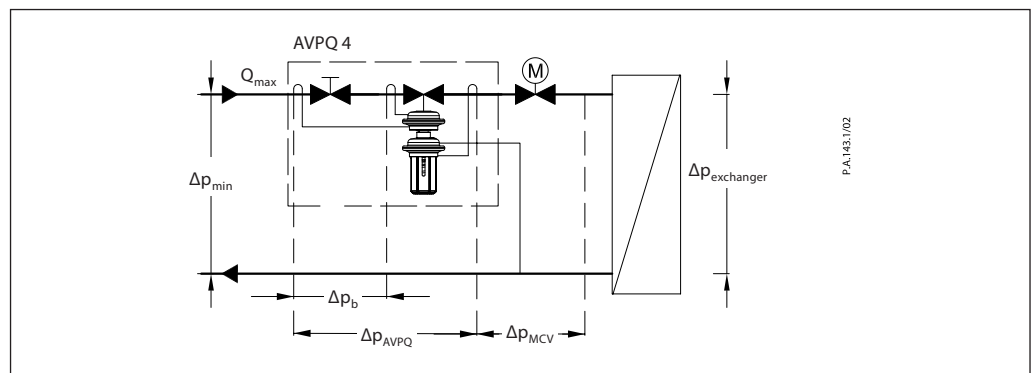
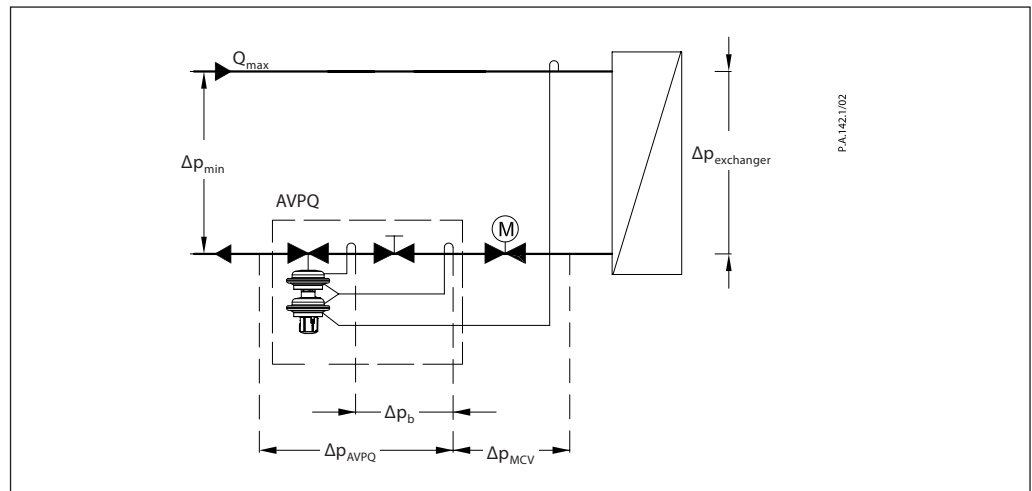

Design

- 1. Cover
- 2. Adjustable flow restrictor
- 3. Valve body
- 4. Valve insert
- 5. Pressure relieved valve cone
- 6. Valve stem
- 7. Control drain
- 8. Control diaphragm for flow control
- 9. Control diaphragm for diff. pressure control
- 10. Setting spring for diff. pressure control
- 11. Handle for diff. pressure setting, prepared for sealing
- 12. Adjuster for diff. pressure setting, prepared for sealing
- 13. Union nut
- 14. Compression fitting for impulse tube
- 15. Upper casing of actuator
- 16. Lower casing of actuator
- 17. Impulse tube
- 18. Excess pressure safety valve
- 19. Actuator

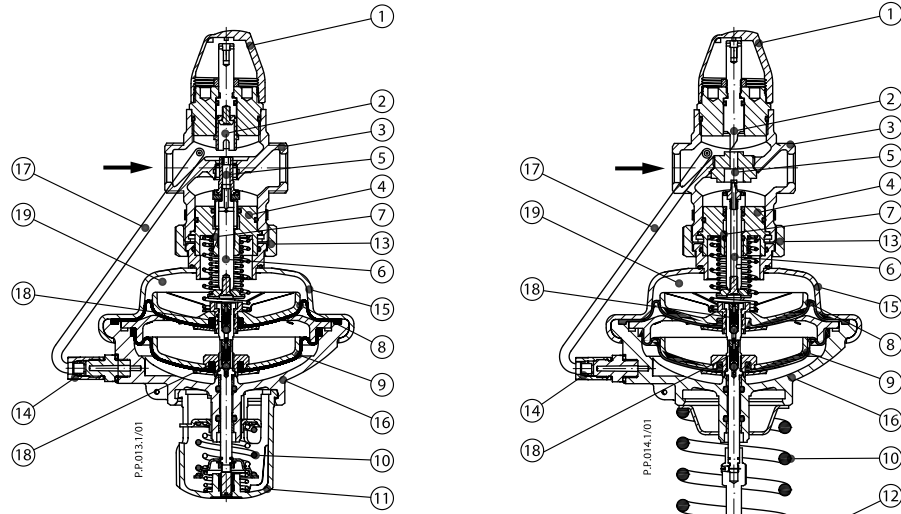

AVPQ (0.2-1.0 bar) - return mounting

AVPQ (0.3-2.0 bar) - return mounting

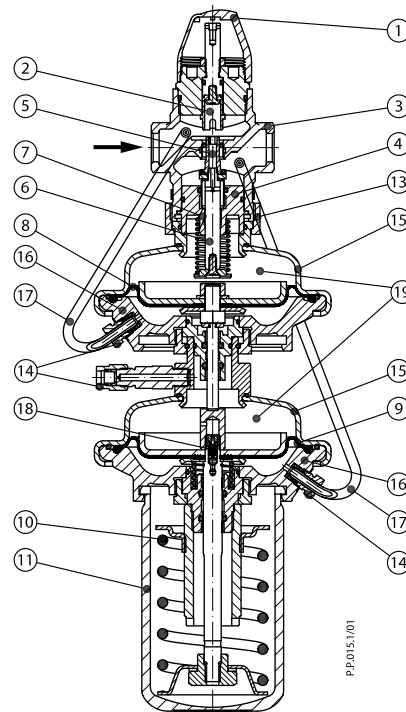

AVPQ 4 - flow mounting

**Function**

Flow volume causes pressure drop across the adjustable flow restrictor. Resulting pressures are being transferred through the impulse tubes and/or control drain in the actuator stem to the actuator chambers and act on control diaphragm for flow control. The flow restrictor diff. pressure is controlled and limited by means of built-in spring for flow control. Control valve closes on rising differential pressure and opens on falling differential pressure to control max flow.

Pressure changes from flow and return pipes are being transferred through the impulse tubes to the actuator chambers and act on control diaphragm for diff. pressure control. The diff. pressure is controlled by means of setting spring for diff. pressure control. Control valve closes on rising differential pressure and opens on falling differential pressure to maintain constant differential pressure.

Controller is equipped with excess pressure safety valve, which protects control diaphragm for diff. pressure control from too high differential pressure. In addition return version of controller is equipped with second excess pressure safety valve, which protects control diaphragm for flow control from too high differential pressure.

**Settings**

*Flow setting*

Flow setting is being done by the adjustment of the flow restrictor position. The adjustment can be performed on the basis of flow adjustment diagram (see relevant instructions) and/or by the means of heat meter.

*Differential pressure setting*

Differential pressure setting is being done by the adjustment of the setting spring for diff. pressure control. The adjustment can be done by means of handle for diff. pressure setting and/or pressure indicators.

**Adjustment diagram**

*Relation between scale figures and differential pressure. Values given are approximate.*

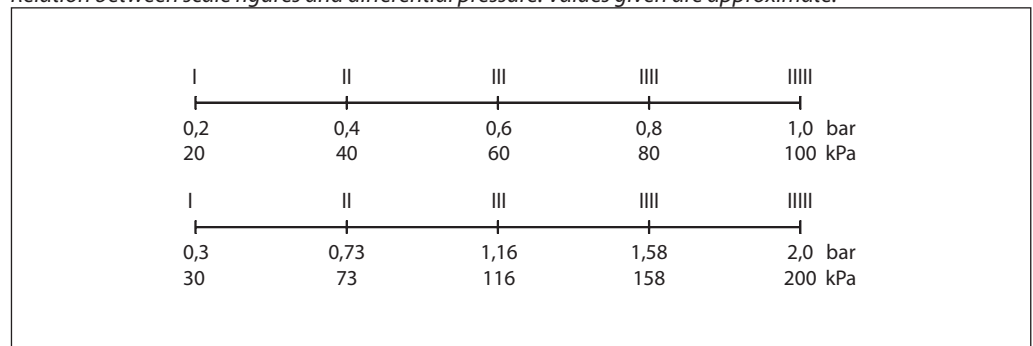

Dimensions

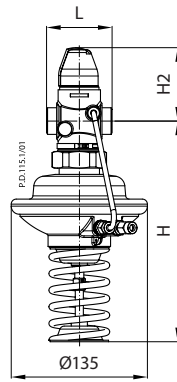

AVPQ  
DN 15-50  
 $\Delta p = 0.3-2.0$  bar

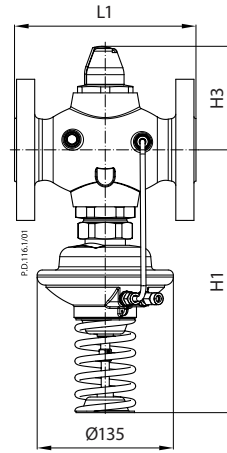

AVPQ  
DN 32-50  
 $\Delta p = 0.3-2.0$  bar

AVPQ ( $\Delta p = 0.3-2.0$  bar)

DN		15	20	25	32	40	50
L	mm	65	70	75	100	110	130
L1		-	-	-	180	200	230
H		219	219	219	260	260	260
H1		-	-	-	260	260	260
H2		73	73	76	103	103	103
H3		-	-	-	103	103	103
Weight (thread)		kg	3.2	3.2	3.4	5.9	6.0
Weight (flange)	-		-	-	10.4	12.0	14.0

Note: Other flange dimensions - see table for tailpieces.

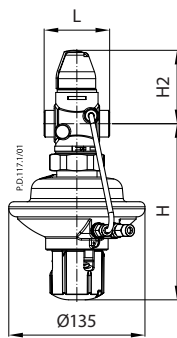

AVPQ  
DN 15-50  
 $\Delta p = 0.2-1.0$  bar

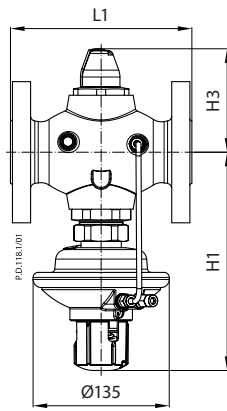

AVPQ  
DN 32-50  
 $\Delta p = 0.2-1.0$  bar

AVPQ ( $\Delta p = 0.2-1.0$  bar)

DN		15	20	25	32	40	50
L	mm	65	70	75	100	110	130
L1		-	-	-	180	200	230
H		175	175	175	217	217	217
H1		-	-	-	217	217	217
H2		73	73	76	103	103	103
H3		-	-	-	103	103	103
Weight (thread)		kg	3.2	3.2	3.4	5.9	6.0
Weight (flange)	-		-	-	10.4	12.0	14.0

Note: Other flange dimensions - see table for tailpieces.

Dimensions (continuous)

AVPQ 4  
DN 15-50
AVPQ 4  
DN 32-50

**AVPQ 4**

DN	15	20	25	32	40	50
L	65	70	75	100	110	130
L1	-	-	-	180	200	230
H	298	298	298	340	340	340
H1	-	-	-	340	340	340
H2	73	73	76	103	103	103
H3	-	-	-	103	103	103
Weight (thread)	5.4	5.4	5.6	8.1	8.2	8.9
Weight (flange)	-	-	-	12.5	14.1	16.2

**Note:** Other flange dimensions - see table for tailpieces.

DN	R <sup>1)</sup>	SW	d	mm						n
				L <sub>1</sub> <sup>2)</sup>	L <sub>2</sub>	L <sub>3</sub>	k	d <sub>2</sub>		
15	½	32 (G ¾A)	21	130	120	139	65	14	4	
20	¾	41 (G 1A)	26	150	131	154	75	14	4	
25	1	50 (G 1¼A)	33	160	145	159	85	14	4	
32	1¼	63 (G 1¾A)	42	-	177	184	100	18	4	
40	1½	70 (G 2A)	47	-	200	204	110	18	4	
50	2	82 (G 2½A)	60	-	244	234	125	18	4	

<sup>1)</sup> Conical ext. thread acc. to EN 10226-1  
<sup>2)</sup> Flanges PN 25, acc. to EN 1092-2

**Compression fittings**

R 1/8 / R 3/8 / R 1/2

