

Data sheet

# Differential pressure and flow controller (PN 16, 25, 40)

**AFPQ / VFQ 2(1)** - return mounting, adjustable setting

**AFPQ 4 / VFQ 2(1)** - flow mounting, adjustable setting

Description

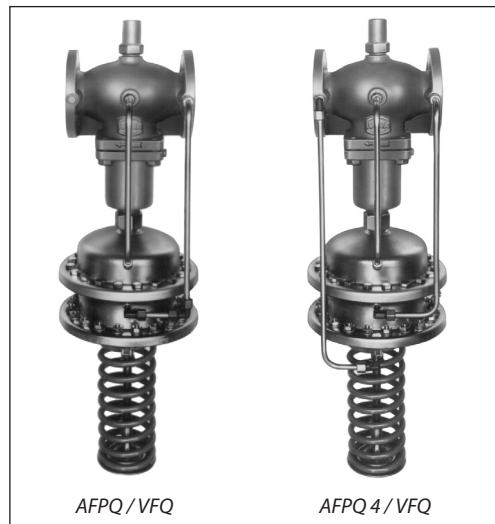

The controller has a control valve with adjustable flow restrictor, an actuator with two control diaphragms and spring for differential pressure setting. Differential pressure control and flow control are independent.

Further on two valve versions are available:

- VFQ 2 with metallic sealing cone
- VFQ 21 with soft sealing cone (on special request)

**Main data:**

- DN 15-250
- $k_{vs}$  4.0-400 m<sup>3</sup>/h
- Flow range: 0.1-250 m<sup>3</sup>/h
- PN 16, 25, 40
- Setting range: 0.1-0.7 bar / 0.15-1.5 bar
- Flow restrictor  $\Delta p_b$ : 0.2 bar or 0.5 bar
- Temperature:
  - Circulation water / glycolic water up to 30 %: 2 ... 150/200 °C
- Connections:
  - Flange

The controller is a self-acting differential pressure and flow controller primarily for use in district heating systems. The controller closes on rising differential pressure or when set max. flow is exceeded.

Ordering

*Example 1:*  
Differential pressure and flow controller; return mounting; DN 15;  $k_{vs}$  4.0; PN 16; metallic sealing; setting range 0.1-0.7 bar; flow restrictor  $\Delta p_b$  0.2 bar;  $T_{max}$  150 °C; flange;

- 1x VFQ 2 DN 15 valve  
Code no: **065B2654**
- 1x AFPQ actuator  
Code no: **003G1029**
- 1x AFPQ DN 15 impulse tubes  
Code no: **003G1365**
- 1x Impulse tube set AF  
Code no: **003G1391**

Products will be delivered separately.

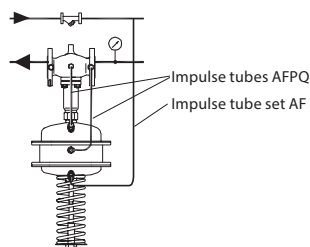

**VFQ 2 Valves (metallic sealing cone)**

Picture	DN (mm)	$k_{vs}$ (m <sup>3</sup> /h)	Connections	$T_{max}$ (°C)	Code No.	$T_{max}$ (°C)	Code No.	
					PN 16		PN 25	PN 40
	15	4.0	Flanges acc. to EN 1092-1	150	<b>065B2654</b>	200 <sup>1)</sup>	<b>065B2667</b>	<b>065B2677</b>
	20	6.3			<b>065B2655</b>		<b>065B2668</b>	<b>065B2678</b>
	25	8.0			<b>065B2656</b>		<b>065B2669</b>	<b>065B2679</b>
	32	16			<b>065B2657</b>		<b>065B2670</b>	<b>065B2680</b>
	40	20			<b>065B2658</b>		<b>065B2671</b>	<b>065B2681</b>
	50	32			<b>065B2659</b>		<b>065B2672</b>	<b>065B2682</b>
	65	50			<b>065B2660</b>		<b>065B2673</b>	<b>065B2683</b>
	80	80			<b>065B2661</b>		<b>065B2674</b>	<b>065B2684</b>
	100	125			<b>065B2662</b>		<b>065B2675</b>	<b>065B2685</b>
	125	160			<b>065B2663</b>		<b>065B2676</b>	<b>065B2686</b>
	150	280		150	<b>065B2664</b>	-	<b>065B2687</b>	
	200	320			<b>065B2758</b>	-	<b>065B2688</b>	
	250	400			<b>065B2759</b>	-	<b>065B2689</b>	

<sup>1)</sup> at temperatures above 150 °C only with seal pots (see Accessories)

**Ordering (continuous)**

*Example 2:*  
 Differential pressure and flow controller; return mounting; DN 15;  $k_{vs}$  4.0; PN 25; metallic sealing; setting range 0.1-0.7 bar; flow restrictor  $\Delta p_b$  0.2 bar;  $T_{max}$  200 °C; flange;

- 1x VFQ 2 DN 15 valve  
Code no: **065B2667**
- 1x AFPQ actuator  
Code no: **003G1029**
- 1x AFPQ DN 15 impulse tubes  
Code no: **003G1365**
- 1x Impulse tube set AF  
Code no: **003G1391**
- 1x Seal pot V1  
Code no: **003G1392**

Products will be delivered separately.

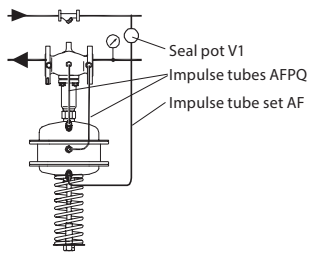

*Example 3:*  
 Differential pressure and flow controller; flow mounting; DN 15;  $k_{vs}$  4.0; PN 25; metallic sealing; setting range 0.1-0.7 bar; flow restrictor  $\Delta p_b$  0.2 bar;  $T_{max}$  200 °C; flange;

- 1x VFQ 2 DN 15 valve  
Code no: **065B2667**
- 1x AFPQ actuator  
Code no: **00G1033**
- 4x Impulse tube set AF  
Code no: **003G1391**
- 3x Seal pot V1  
Code no: **003G1392**

Products will be delivered separately.

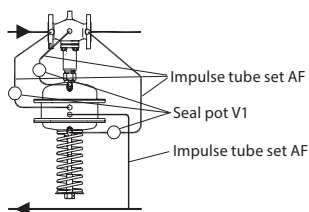

**AFPQ / AFPQ 4 Actuators**

Picture	$\Delta p$ setting range (bar)	Flow restrictor $\Delta p_b$ (bar)	Nominal pressure (PN)	Code No.	
				AFPQ (return)	AFPQ 4 (flow)
	0.1-0.7	0.2	40	<b>003G1029</b>	<b>003G1033</b>
		0.5		<b>003G1030</b>	<b>003G1034</b>
	0.15-1.5	0.2		<b>003G1031</b>	<b>003G1035</b>
		0.5		<b>003G1032</b>	<b>003G1036</b>

**Accessories**

Picture	Type designation	For controller	DN (mm)	PN	Code No.				
	Impulse tubes <sup>3)</sup> (Stainless steel)	AFPQ	15	16, 25, 40	<b>003G1365</b>				
			20						
			25						
			32		<b>003G1367</b>				
			40						
			50						
			65		<b>003G1369</b>				
			80						
			100						
			125		<b>003G1370</b>				
			150						
			200			16	<b>003G1371</b>		
					Impulse tubes <sup>3)</sup> (Stainless steel)	AFPQ 4	200	40	<b>003G1373</b>
							250	16	<b>003G1374</b>
							15	16, 25, 40	<b>003G1416</b>
<b>003G1375</b>									
<b>003G1376</b>									
20	16, 25, 40	<b>003G1417</b>							
		<b>003G1378</b>							
		<b>003G1380</b>							
25	16, 25, 40	<b>003G1382</b>							
		<b>003G1383</b>							
		<b>003G1384</b>							
32	16, 25, 40	<b>003G1386</b>							
		<b>003G1387</b>							
		<b>003G1388</b>							
40	16, 25, 40	<b>003G1418</b>							
		<b>003G1384</b>							
		<b>003G1386</b>							
50	16, 25, 40	<b>003G1387</b>							
		<b>003G1388</b>							
		<b>003G1419</b>							
65	16, 25, 40	<b>003G1384</b>							
		<b>003G1386</b>							
		<b>003G1387</b>							
80	16, 25, 40	<b>003G1388</b>							
		<b>003G1418</b>							
		<b>003G1389</b>							
100	16, 25, 40	<b>003G1419</b>							
		<b>003G1384</b>							
		<b>003G1386</b>							
125	16, 25, 40	<b>003G1387</b>							
		<b>003G1388</b>							
		<b>003G1406</b>							
150	16, 25, 40	<b>003G1418</b>							
		<b>003G1389</b>							
		<b>003G1419</b>							
200	16, 25, 40	<b>003G1419</b>							
		<b>003G1389</b>							
		<b>003G1406</b>							
250	16, 25, 40	<b>003G1419</b>							
		<b>003G1389</b>							
		<b>003G1406</b>							

Picture	Type designation	Description	Ordering number	Code No.
	Impulse tube set AF	- 1x Copper tube $\varnothing 10 \times 1 \times 1500$ mm - 1 x compression fitting for imp. tube connection to pipe (G 1/4) - 2 x socket	-	<b>003G1391</b>
	Seal pot V1 <sup>1)</sup>	Capacity 1 liter; with compression fittings for imp. tube $\varnothing 10$	AFPQ 1x AFPQ 4 3x	<b>003G1392</b>
	Compression fitting <sup>2)</sup>	For impulse tube $\varnothing 10$ connections to controller	G 1/4	<b>003G1468</b>
	Combination piece KF3	For combination with pressure and electrical actuators	G 1 1/4 / 2x G 1 1/4	<b>003G1397</b>
	Combination piece KF2	For combination with thermostat		<b>003G1398</b>
	Shut off valve	For impulse tube $\varnothing 10$	-	<b>003G1401</b>
	Throttle valve			<b>065B2909</b>

<sup>1)</sup> Seal pot has to be used on impulse tubes always when  $T_{max} \geq 150$  °C

<sup>2)</sup> Consist of a nipple, compression ring and nut

<sup>3)</sup> With combination piece KF2 or KF3 use 2x **003G1391** at PN 16 and  $T < 150$  °C. Otherwise impulse tubes on special request.

Ordering (continuous)

Service kits

Picture	Type designation	For valve	DN (mm)	k <sub>vs</sub> (m <sup>3</sup> /h)	Code No.
	Valve insert	VFQ 2	15	4.0	065B2796
			20	6.3	065B2797
			25	8	065B2798
			32	16	
			40	20	065B2799
			50	32	
			65	50	065B2800
			80	80	
			100	125	065B2801
			125	160	
150	280	065B2964			
250	400	065B2965			
	Stuffing cone (with EPDM O-rings)				003G1464

Technical data

Valve

Nominal diameter		DN	15	20	25	32	40	50	65	80	100	125	150	200	250	
k <sub>vs</sub> value of Δp controller			4.0	6.3	8.0	16	20	32	50	80	125	160	280	320	400	
Range of max. flow setting	Δp <sub>b</sub> <sup>1)</sup> = 0.2 bar	from	0.1	0.2	0.2	0.4	0.6	0.8	3	4	6	8	12	15	18	
		to	2	3	4	7	11	16	28	40	63	80	125	150	180	
	Δp <sub>b</sub> <sup>1)</sup> = 0.5 bar	from	0.2	0.3	0.3	0.5	0.8	1.2	4	6	9	12	18	22	25	
		to	3	4.5	6	10	16	24	40	58	90	120	180	220	250	
Cavitation factor z			0.6	0.6	0.6	0.55	0.55	0.5	0.5	0.45	0.4	0.35	0.3	0.2	0.2	
Leakage acc. to standard IEC 534 (% of k <sub>vs</sub> )		VFQ 2	≤ 0.03										≤ 0.05			
		VFQ 21	≤ 0.01													
Nominal pressure		PN	16, 25, 40													
Min. differential pressure for max flow <sup>2)</sup>	Δp <sub>b</sub> <sup>1)</sup> = 0.2	bar	0.5	0.4	0.5	0.4	0.5					0.4				
	Δp <sub>b</sub> <sup>1)</sup> = 0.5		0.8	0.7	0.8	0.7	0.8					0.7				
Max. differential pressure	PN 16	bar	16								15	12	10			
	PN 25, 40		20													
Media		Circulation water / glycolic water up to 30 %														
Media pH		Min. 7, max. 10														
Media temperature	VFQ 2	°C	2 ... 150/2 ... 200 <sup>3)</sup>										2 ... 150			
	VFQ 21		2 ... 150													
Connections		Flange														
<b>Materials</b>																
Valve body	PN 16	Grey cast iron EN-GJL-250 (GG-25)														
	PN 25	Ductile iron EN-GJS-400(GGG-40.3)														
	PN 40	Cast steel GP240GH (GS-C 25)														
Valve seat		Stainless steel, mat. No. 1.4021											Stainless steel, mat. No. 1.4313			
Valve cone		Stainless steel, mat. No. 1.4404											Stainless steel, mat. No. 1.4021			
Sealing	VFQ 2	Metal														
	VFQ 21	EPDM														
Pressure relieve system		Bellows (Stainless steel, mat. No. 1.4571)											Diaphragm (EPDM)			

<sup>1)</sup> Δp<sub>b</sub> – differential pressure over flow restrictor

<sup>2)</sup> For flows smaller than Q<sub>max</sub> → Δp<sub>min</sub> =  $\left(\frac{Q}{k_{vs}}\right)^2 + \Delta p_b$

<sup>3)</sup> at temperatures above 150 °C only with seal pots (see Accessories)

Technical data (continuous)

Actuator

Type		AFPQ, AFPQ 4	
Actuator size	cm <sup>2</sup>	250	
Nominal pressure	PN	40	
Flow restrictor diff. pressure $\Delta p_b$		0.2 / 0.5	
Diff. pressure setting ranges and spring colours	bar	0.1-0.7	0.15-1.5
		yellow	red
<b>Materials</b>			
Actuator housing		Steel, mat. No.1.0338, zinc plated	
Control diaphragm		EPDM (Rolling; fibre enforced)	

Application principles

– Return mounting

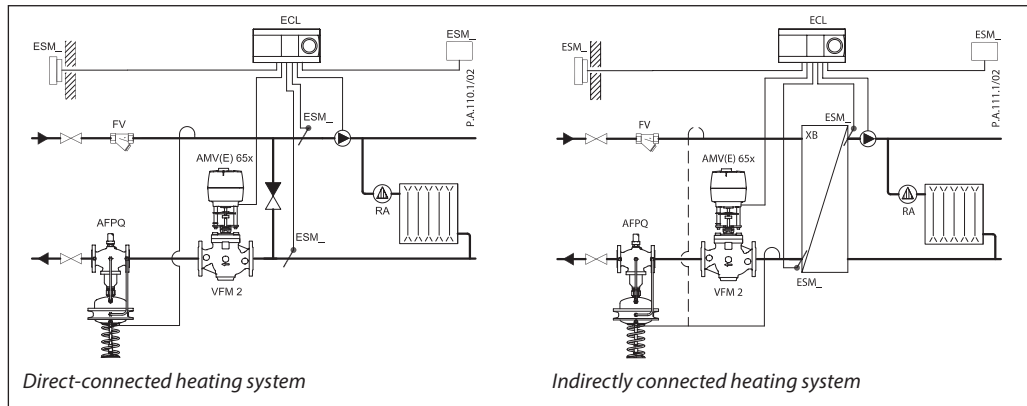

– Flow mounting

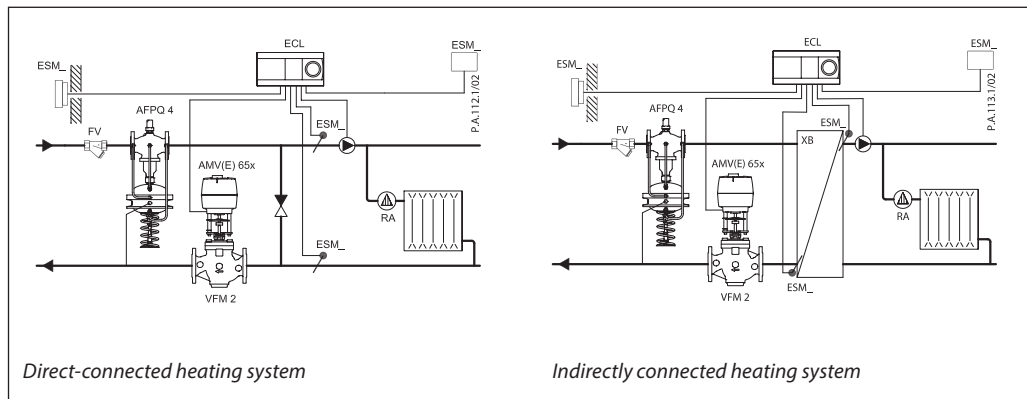

**Combinations**

Example:  
 Differential pressure, flow and temperature controller, return mounting; DN 15;  $k_{vs}$  4.0; PN 16; metallic sealing; setting range 0.1-0.7 bar; flow restrictor  $\Delta p_b$  0.2 bar;  $T_{max}$  150 °C; flange;

- 1x VFQ 2 DN 15 valve  
Code no: **065B2654**
- 1x AFPQ actuator  
Code no: **003G1029**
- 3x Impulse tube set AF  
Code no: **003G1391**
- 1x AFT06 thermostat  
Code no: **065-4390**
- 1x Combination piece KF2  
Code no: **003G1398**

Products will be delivered separately.

**Note:**  
 For AFT 06 thermostat data see relevant data sheet

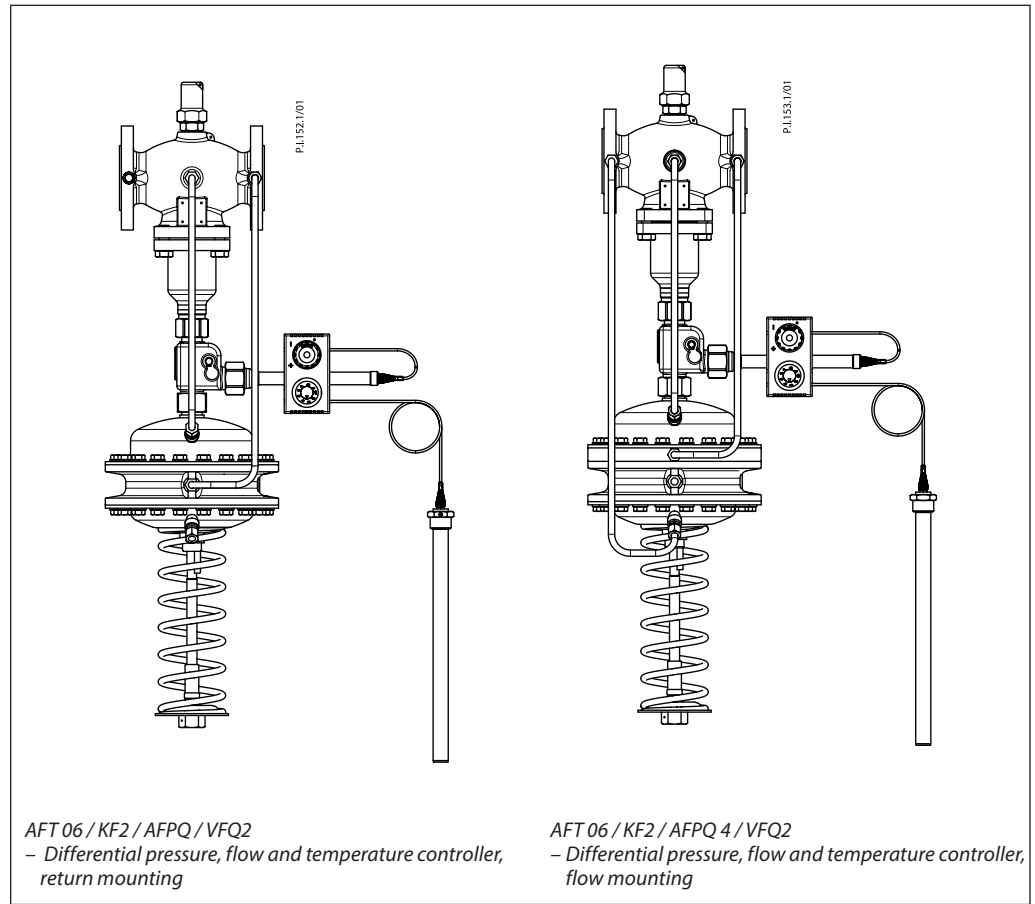

**Installation positions**

DN 15-80  $T_{max} \leq 120$  °C

The controllers can be installed in any position.

DN 15-80  $T_{max} > 120$  °C; DN 100-250

The controllers can be installed in horizontal pipes only, with a pressure actuator oriented downwards.

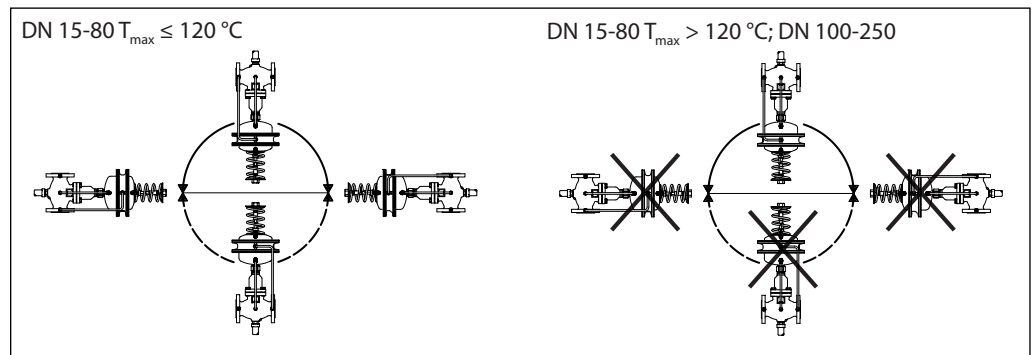

**Pressure temperature diagram**

Working area is below P-T line and it ends at T<sub>max</sub> for each valve

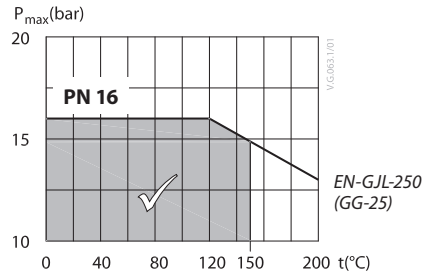

Maximum allowed operating pressure as a function of media temperature (according to EN 1092-2)

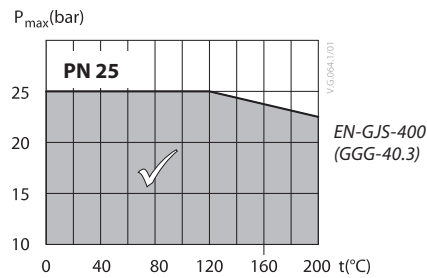

Maximum allowed operating pressure as a function of media temperature (according to EN 1092-2)

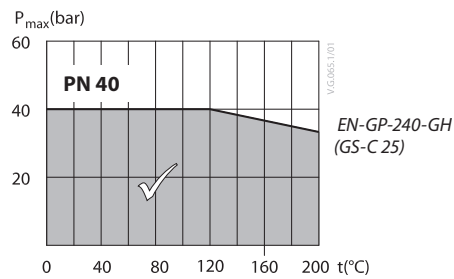

Maximum allowed operating pressure as a function of media temperature (according to EN 1092-1)

**Sizing**

- Directly connected heating system

**Example 1**

Motorised control valve (MCV) for mixing circuit in direct-connected heating system requires differential pressure of 0.3 bar (30 kPa) and flow less than 1.900 l/h.

Possible pipe pressure losses in tubes, shut-off fittings, heatmeters, etc. are not included.

$k_v$  value is calculated according to formula:

$$k_v = \frac{Q_{max}}{\sqrt{\Delta p_{AFPQ} - \Delta p_b}} = \frac{1,9}{\sqrt{0,6 - 0,2}}$$

$$k_v = 3.0 \text{ m}^3/\text{h}$$

**Given data:**

$$Q_{max} = 1.9 \text{ m}^3/\text{h} (1.900 \text{ l/h})$$

$$\Delta p_{min} = 0.9 \text{ bar (90 kPa)}$$

$$\Delta p_{circuit}^{1)} = 0.1 \text{ bar (10 kPa)}$$

$$\Delta p_{MCV} = 0.3 \text{ bar (30 kPa) selected}$$

$$\Delta p_b^{2)} = 0.2 \text{ bar (20 kPa)}$$

**Remark:**

<sup>1)</sup>  $\Delta p_{circuit}$  corresponds to the required pump pressure in the heating circuit and is not to be considered when sizing the AFPQ(4).

<sup>2)</sup>  $\Delta p_b$  is differential pressure over flow restrictor.

**Solution:**

The example selects AFPQ 4 DN 15,  $k_{vS}$  value 4.0, with differential pressure setting range 0.1-0.7 bar, flow setting range 0.1-2.0 m<sup>3</sup>/h.

The differential pressure set value is:

$$\Delta p_{set \text{ value}} = \Delta p_{MCV}$$

$$\Delta p_{set \text{ value}} = 0.3 \text{ bar (30 kPa)}$$

The total pressure loss across the controller is:

$$\Delta p_{AFPQ} = \Delta p_{min} - \Delta p_{MCV} = 0.9 - 0.3$$

$$\Delta p_{AFPQ} = 0.6 \text{ bar (60 kPa)}$$

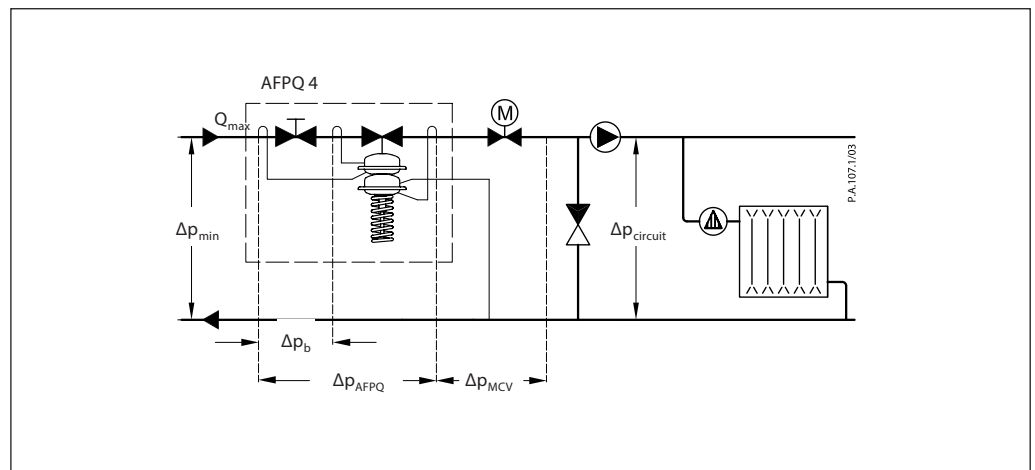
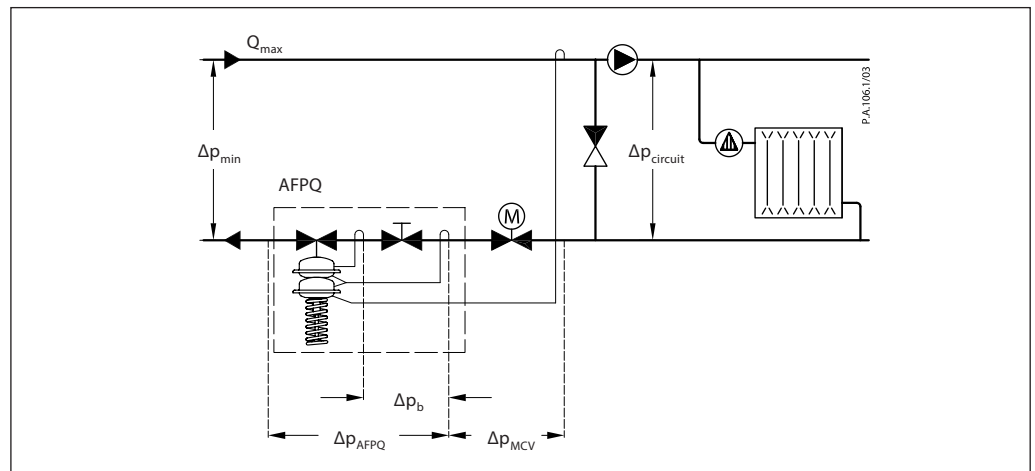

**Sizing (continuous)**

- Indirectly connected heating system

**Example 2**

Motorised control valve (MCV) for indirectly connected heating system requires differential pressure of 0.3 (30 kPa) bar and flow less than 1.800 l/h.

*Given data:*

- $Q_{max} = 1.8 \text{ m}^3/\text{h} \text{ (1.800 l/h)}$
- $\Delta p_{min} = 1.0 \text{ bar (100 kPa)}$
- $\Delta p_{exchanger} = 0.05 \text{ bar (5 kPa)}$
- $\Delta p_{MCV} = 0.3 \text{ bar (30 kPa)}$  selected
- $\Delta p_b^{1)} = 0.2 \text{ bar (20 kPa)}$

*Remark:*

<sup>1)</sup>  $\Delta p_b$  is differential pressure over flow restrictor

The differential pressure set value is:

- $\Delta p_{set \text{ value}} = \Delta p_{exchanger} + \Delta p_{MCV}$
- $\Delta p_{set \text{ value}} = 0.05 + 0.3$
- $\Delta p_{set \text{ value}} = 0.35 \text{ bar (35 kPa)}$

The total pressure loss across the controller is:

$$\begin{aligned} \Delta p_{AFPQ} &= \Delta p_{min} - \Delta p_{exchanger} - \Delta p_{MCV} \\ \Delta p_{AFPQ} &= 1.0 - 0.05 - 0.3 \\ \Delta p_{AFPQ} &= 0.65 \text{ bar (65 kPa)} \end{aligned}$$

Possible pipe pressure losses in tubes, shut-off fittings, heatmeters, etc. are not included.

$k_v$  value is calculated according to formula:

$$k_v = \frac{Q_{max}}{\sqrt{\Delta p_{AFPQ} - \Delta p_b}} = \frac{1,8}{\sqrt{0,65 - 0,2}}$$

$$k_v = 2.7 \text{ m}^3/\text{h}$$

*Solution:*

The example selects AFPQ 4 DN 15,  $k_{vS}$  value 4.0, with differential pressure setting range 0.1-0.7 bar, flow setting range 0.1-2.0  $\text{m}^3/\text{h}$ .

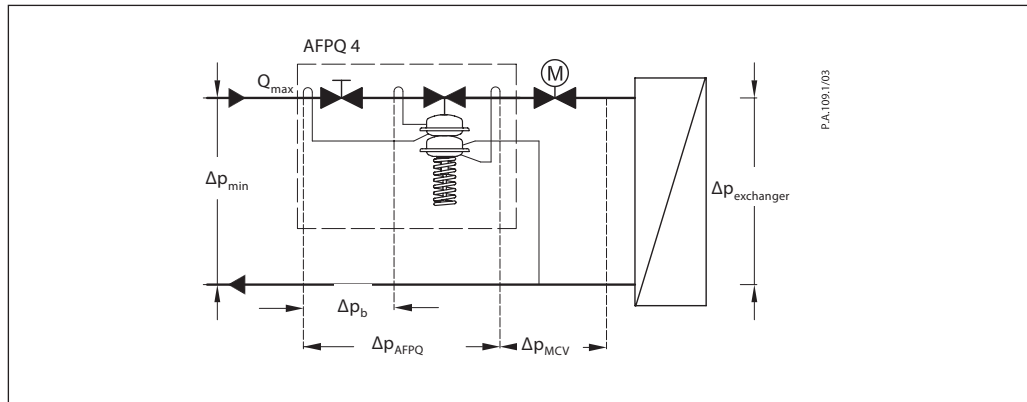
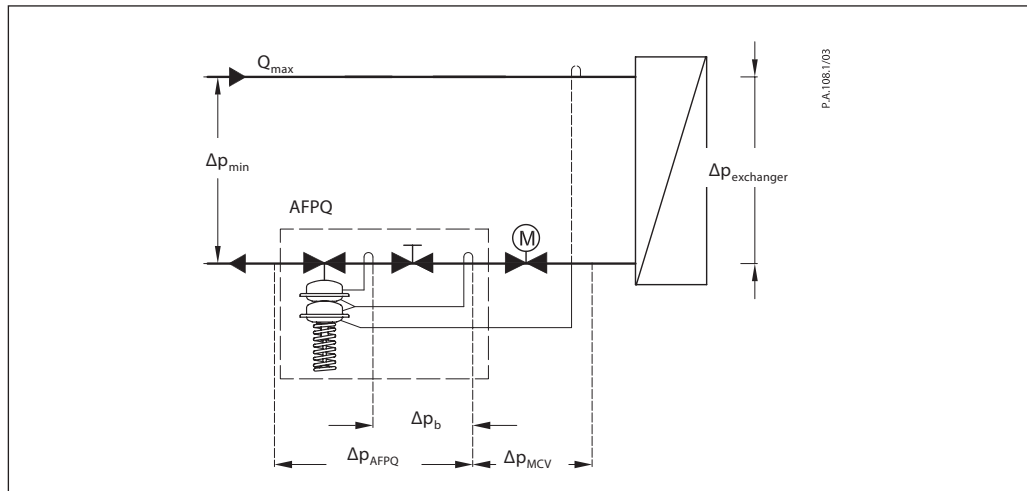

**Design**

1. Valve body
2. Cover
3. Adjustable flow restrictor
4. Valve seat
5. Valve insert
6. Pressure relieved valve cone
7. Valve stem
8. Bellows for pressure relief of valve cone
9. Diaphragm for pressure relief of valve cone
10. Actuator
11. Control diaphragm for flow control
12. Control diaphragm for diff. pressure control
13. Excess pressure safety valve
14. Built-in spring for flow control
15. Setting spring for diff. pressure control
16. Adjuster for diff. pressure setting, prepared for sealing
17. Stuffing cone
18. Union nut
19. Impulse tube
20. Compression fitting for impulse tube
21. Upper casing of diaphragm
22. Lower casing of diaphragm
23. Valve body extension
24. Shut off valve for water filling
25. Closing plug

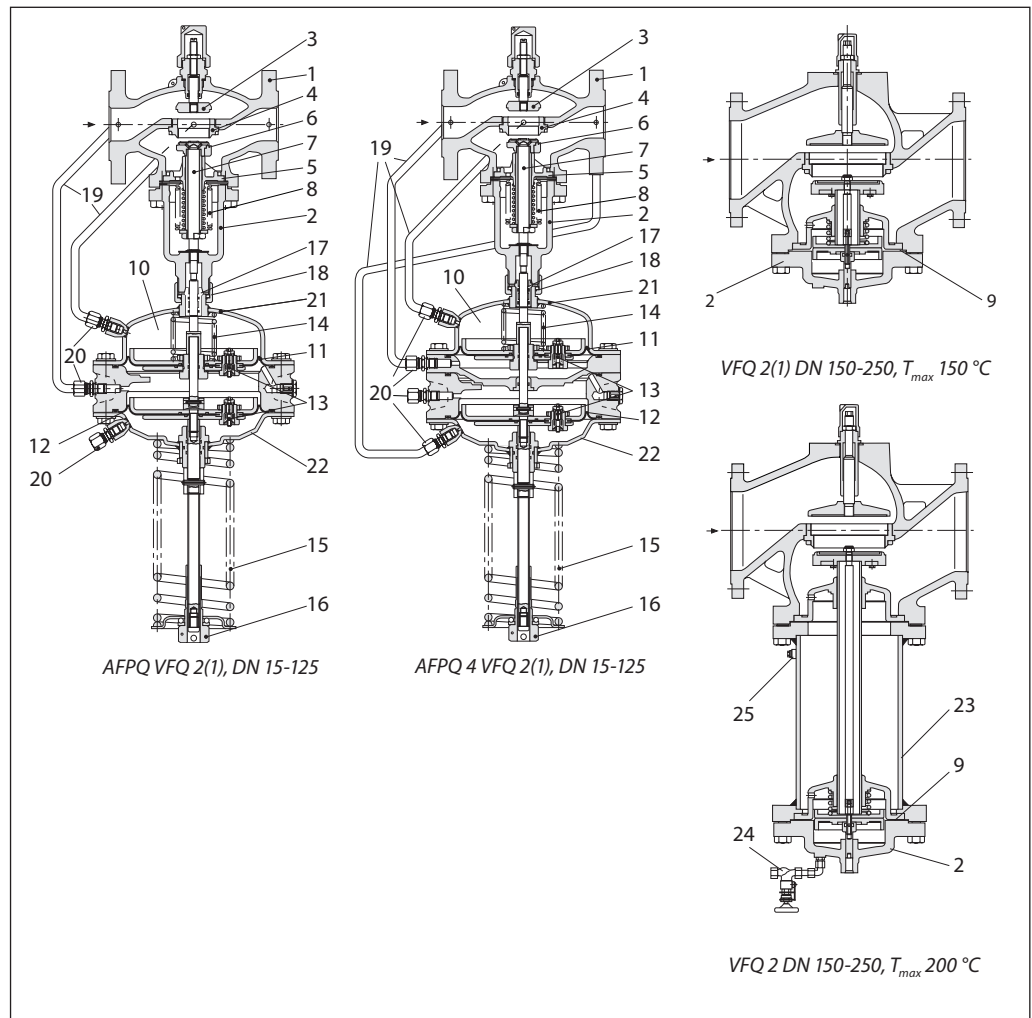

**Function**

Flow volume causes pressure drop across the adjustable flow restrictor. Resulting pressures are being transferred through the impulse tubes to the actuator chambers and act on control diaphragm for flow control. The flow restrictor diff. pressure is controlled and limited by means of built-in spring for flow control. Control valve closes on rising differential pressure and opens on falling differential pressure to control max flow.

Pressure changes from flow and return pipes are being transferred through the impulse tubes to the actuator chambers and act on control diaphragm for diff. pressure control. The diff. pressure is controlled by means of setting spring for diff. pressure control. Control valve closes on rising differential pressure and opens on falling differential pressure to maintain constant differential pressure.

Controller is equipped with two excess pressure safety valves, which protect control diaphragms for flow and diff. pressure control from too high differential pressure.

**Setting**

*Flow setting*

Flow setting is being done by the adjustment of the flow restrictor position. The adjustment can be performed on the basis of flow adjustment diagram (see relevant instructions) and/or by the means of heat meter.

*Differential pressure setting*

Differential pressure setting is being done by the adjustment of the setting spring for diff. pressure control. The adjustment can be done by means of adjuster for diff. pressure setting and pressure indicators.

Dimensions

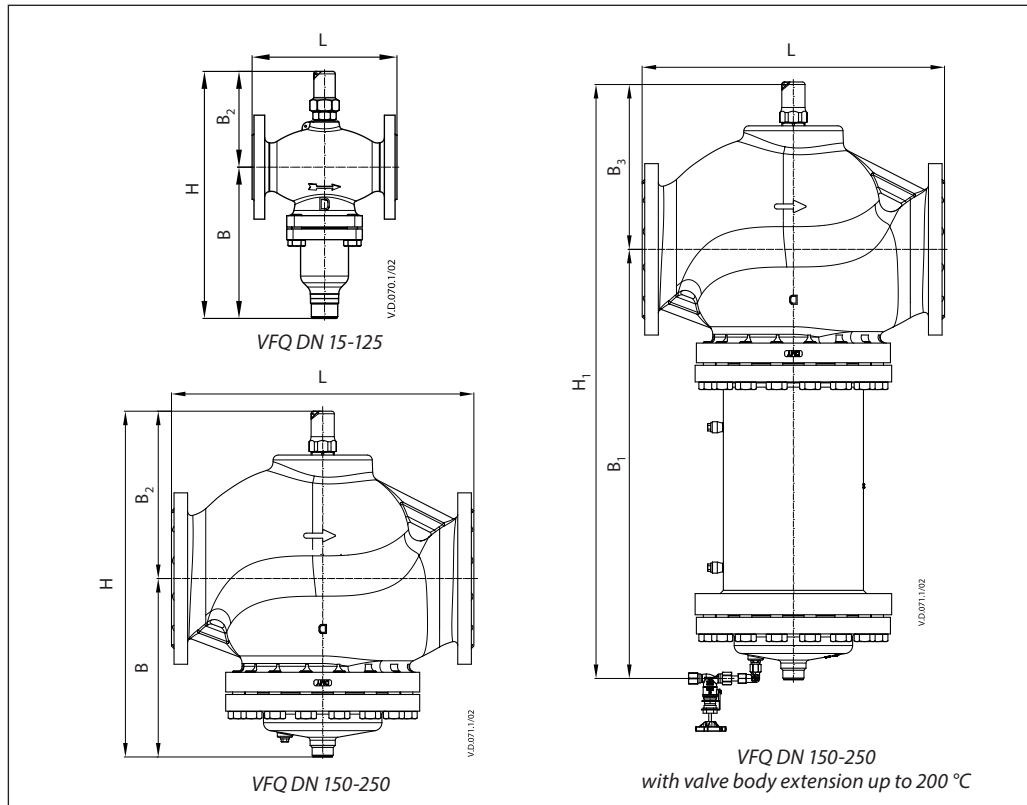

VFQ 2, VFQ 21 Valves

DN		15	20	25	32	40	50	65	80	100	125	150	200	250		
L	mm	130	150	160	180	200	230	290	310	350	400	480	600	730		
B		213	213	239	239	241	241	276	276	381	381	326	354	401		
B <sub>2</sub>		124	124	135	135	152	152	164	164	194	194	269	332	355		
H		337	337	374	374	393	393	440	440	575	575	595	686	756		
Weight	PN 16 / 25	kg	8	9	10.5	12.5	15.5	18.5	28.5	31	61	71	120	193	337	
	PN 40		31	34	63	72	147	264	347							
B <sub>1</sub>	mm												620	852	1199	
B <sub>3</sub>													269	332	356	
H <sub>1</sub>													889	1184	1555	
Weight (valve with body extension)	PN 16 / 25	kg												160	314	489
	PN 40		187	350	526											

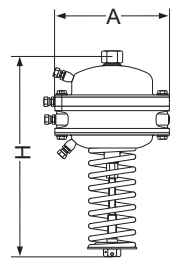

AFPQ, AFPQ 4 Actuators

Actuator type		AFPQ / AFPQ 4
∅ A	mm	257
H for xs = 0.1-0.7 / 0.15-1.5		520/540
Weight	kg	34

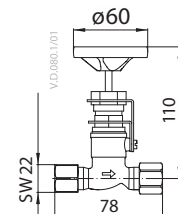

Shut off valve

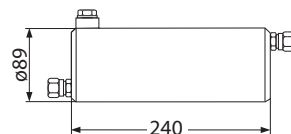

Seal pot V1

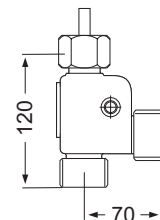

Comb. piece KF2, KF3

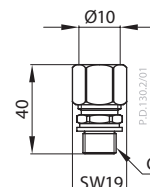

Compression fitting



