

Diff. pressure relief controller (PN 10) AVDA - internal thread

Description



AVDA is self-acting differential pressure relief controller used for constant flow control or bypass control. Controller opens on rising differential pressure.

The controller has a control valve, an actuator with one control diaphragm and handle for differential pressure setting.

For apartment block heating, district heating plant and central heating systems.

Main data:

- DN 15, 20, 25
- k_{vs} 1.9, 3.4, 5.5
- PN 10
- Setting range: 0.1 - 1.2 bar
- Temperature:
 - Circulation water / glycolic water up to 30%: -25 ... 130 °C
- Connections: Int. thread

Ordering

Example:
Differential pressure relief controller, DN 15, k_{vs} 1.9, PN 10, setting range 0.1 - 1.2, t_{max} 130°C, int. thread

- 1x AVDA DN 15 controller
Code No: **003N0038**

AVDA Controller

Picture	DN	k_{vs} (m ³ /h)	PN	Setting range (bar)	Connection- valve (Int. thread ISO 7/1)	Connection - Impulse tube flare	Code No. ¹⁾
	15	1.9	10	0.1 - 1.2	Rp 1/2	7/16-20 UNF	003N0038
	20	3.4			Rp 3/4		003N0039
	25	5.5			Rp 1		003N0040

¹⁾ The code no. includes 2 impulse tubes (0.5 and 1.5 m) with compression fitting.

Service kits

Picture	Type designation	DN	Code No.
	Repair set Two diaphragms, two O-rings, one rubber cone, one tube of grease and eight valve cover screws	15	003N4006
		20	003N4007
		25	003N4008
	Valve body (int. thread)	15	003N2030
		20	003N2040
		25	003N2050
	Nipple for impulse tube connection to pipe		631X4700
	Valve stuffing box		065F0006
	Diaphragm housing		003N0065

Technical data

Nominal diameter	DN	15	20	25
k_{vs} value	m ³ /h	1.9	3.4	5.5
Cavitation factor z			0.4	
Nominal pressure	PN	10		
Max. differential pressure	bar	7		
Medium		Circulation water / glycolic water up to 30%		
Medium pH		Min. 7, max. 10		
Medium temperature	°C	-25 ... +130 °C		
Connections (valve)		Internal thread		
Materials				
Valve body		MS 58, hot-pressed, DIN 17660, W.No. 2.0402, CuZn40Pb2		
Valve seat		Cr Ni steel, DIN 17660, W.No. 1.4301		
Valve cone		NBR-rubber		
Spindle		Dezincing-free brass, BS 2874/CZ132		
Diaphragm housing		Zinc-cromated steel, DIN 1624, W.No. 1.0338		
Diaphragm		EPDM-rubber		

Application principles

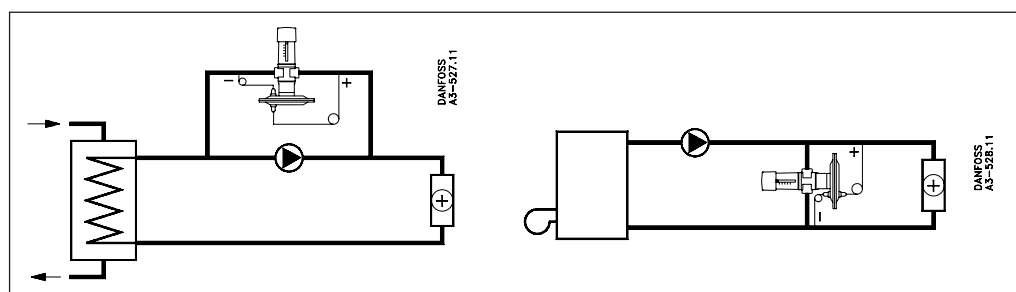

Installation positions

The valve body can be installed in any position. A Danfoss FV strainer is recommended.

Impulse tubes have to be installed vertically or horizontally onto the main pipe, never downwards.

Needle valve can be installed between main pipe and impulse tube, if necessary.

(+) impulse tube has to be connected to flow line, (-) impulse tube has to be connected to return line. Setting can be simplified by using pressure indicators (manometers) placed close to impulse tube connections.

By turning diaphragm housing downwards the letter "RA" on valve housing must be oriented upright.

Design

1. Handle for differential pressure setting
2. Spring housing
3. Setting spring
4. Spring guide
5. Diaphragm
6. Valve cone
7. Spindle
8. O-ring
9. O-ring gland
10. Diaphragm housing
11. Control diaphragm
12. Nipple for impulse tube
13. Lead seal

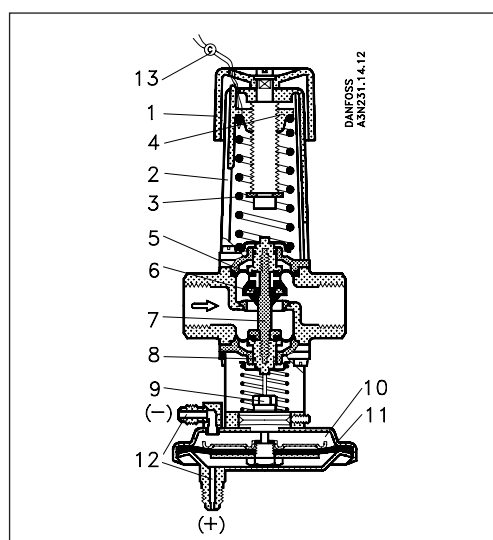

Sizing

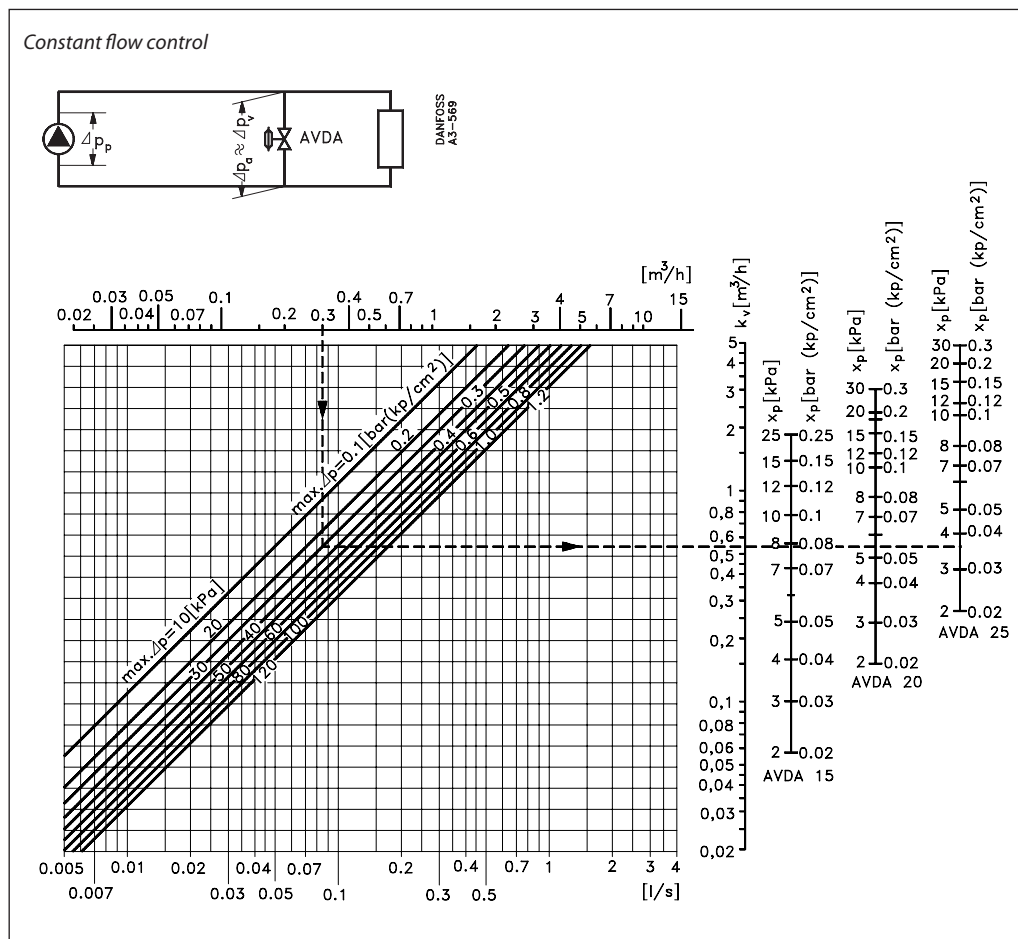

Example

Given

Assuming a pressure drop in the line from the pump to and from the valve connections of nil so that $\Delta p_p = \Delta p_a = \Delta p_v$, the plant differential pressure at max. load = 0.25 bar.

Condition

Maximum plant differential pressure with closed radiator valves limited to 0.3 bar. Pump water volume (Q) for this condition = 0.3 m³/h.

Required

A pressure relief control able to circulate a water volume of at least 0.3 m³/h at $\Delta p_a = 0.3$ bar and which will remain closed under max. plant load, $\Delta p_a = 0.25$ bar.

Method

Locate the necessary water volume, $Q = 0.3$ m³/h, on the horizontal axis in the nomogram.

From the 0.3 m³/h point, take a vertical line up to intersect the curve that gives the pressure at which the valve must be completely open (here, 0.3 bar). From the intersection, take a horizontal line to intersect the vertical axes on the right. These axes give the pressure rise X_p that is necessary across the valve before it can give the required capacity Q.

Since the pressure rise in this example is $0.3 - 0.25 = 0.05$ bar, a valve where $X_p \leq 0.05$ bar could be used, i.e. an AVDA 25.

This setting is therefore 0.25 bar, i.e. the valve is closed when the differential pressure across it is 0.25 bar.

A pressure gauge can be used in making the setting, or an approximate setting can be made as shown in the associated installation example.

Settings

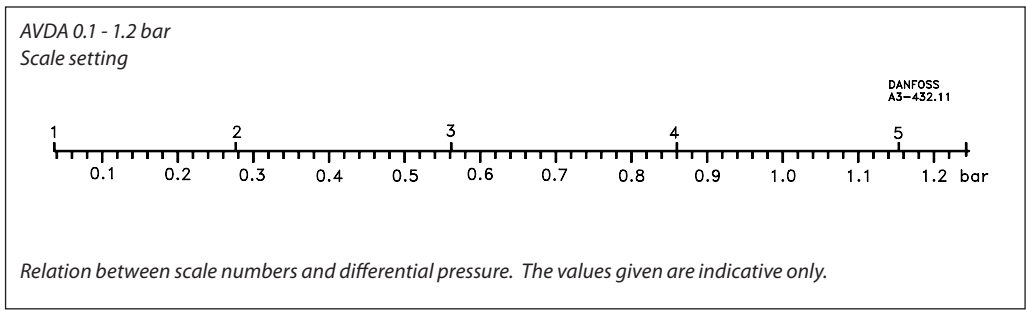

Dimensions

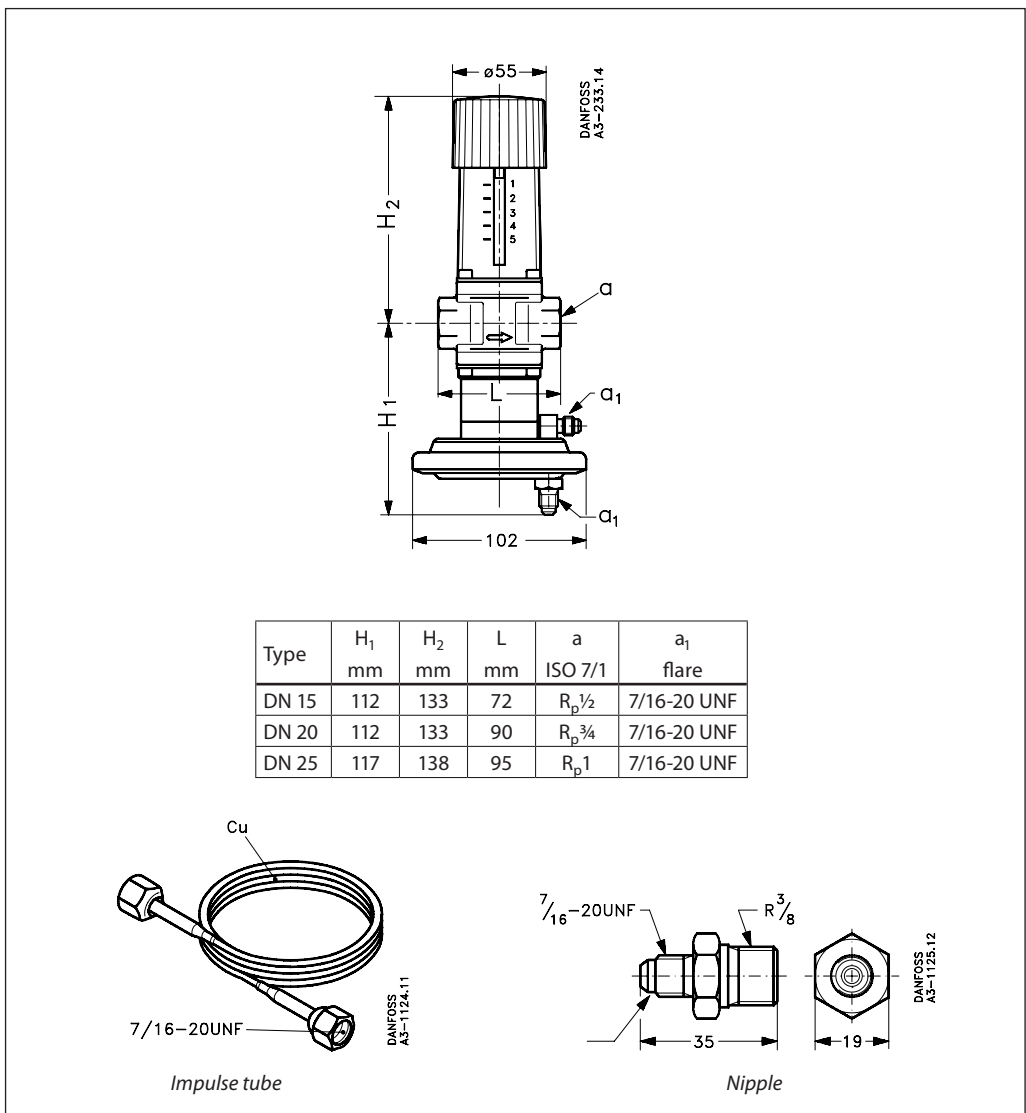

Danfoss can accept no responsibility for possible errors in catalogues, brochures and other printed material. Danfoss reserves the right to alter its products without notice. This also applies to products already on order provided that such alterations can be made without subsequential changes being necessary in specifications already agreed. All trademarks in this material are property of the respective companies. Danfoss and the Danfoss logotype are trademarks of Danfoss A/S. All rights reserved.