

Data sheet

Pressure relief controller AVA (PN 25)

Description



AVA is a self-acting pressure relief controller primarily for use in district heating systems. The controller is normally closed and opens on rising pressure.

The controller has a control valve, an actuator with one control diaphragm and a spring(s) for pressure setting.

Main data:

- DN 15-50
- k_{vs} 4,0-25 m³/h
- PN 25
- Setting range:
1,0-4,5 bar / 3,0-11 bar
- Temperature:
 - Circulation water / glycolic water up to 30 %: 2 ... 150 °C
- Connections:
 - Ext. thread (weld-on, thread and flange tailpieces)
 - Flange

Ordering

Example:
Pressure relief controller; DN 15;
 k_{vs} 4,0; PN 25; setting range
1,0-4,5 bar; T_{max} 150 °C; ext. thread

- AVA DN 15 controller
Code No: **003H6614**

Option:
- Weld-on tailpieces
Code No: **003H6908**

The controller will be delivered completely assembled, inclusive impulse tubes between valve and actuator.

AVA Controller

Picture	DN (mm)	k_{vs} (m ³ /h)	Connection		Pressure setting range (bar)	Code No.	Pressure setting range (bar)	Code No.
	15	4,0	Cylindr. ext. thread acc. to ISO 228/1	G 3/4 A	1,0-4,5	003H6614	3-11	003H6620
	20	6,3		G 1 A		003H6615		003H6621
	25	8,0		G 1 1/4 A		003H6616		003H6622
	32	12,5	Flanges PN 25, acc. to EN 1092-2			003H6626		003H6629
	40	20				003H6627		003H6630
	50	25				003H6628		003H6631

Note: other controllers available on special request.

Accessories

Picture	Type designation	DN	Connection	Code No.
	Weld-on tailpieces	15	-	003H6908
		20		003H6909
		25		003H6910
	External thread tailpieces	15	Conical ext. thread acc. to EN 10226-1	R 1/2 003H6902
		20		R 3/4 003H6903
		25		R 1 003H6904
	Flange tailpieces	15	Flanges PN 25, acc. to EN 1092-2	003H6915
		20		003H6916
		25		003H6917

Ordering (continuous)
Service kits

Picture	Type designation	Pressure setting range (bar)	Code No.
	Actuator with setting spring	1,0-4,5	003H6844
		3-11	003H6845

Technical data
Valve

Nominal diameter	DN	15	20	25	32	40	50
k _{vs} value	m ³ /h	4,0	6,3	8,0	12,5	20	25
Cavitation factor z		≥ 0,6		≥ 0,55		≥ 0,5	
Leakage acc. to standard IEC 534	% of k _{vs}	≤ 0,02			≤ 0,05		
Nominal pressure	PN	25					
Max. differential pressure	bar	20			16		
Medium		Circulation water / glycolic water up to 30 %					
Medium pH		Min. 7, max. 10					
Medium temperature	°C	2 ...150					
Connections	valve	External thread			Flange		
	tailpieces	Weld-on, external thread and flange			-		
Materials							
Valve body	thread	Red bronze CuSn5ZnPb (Rg5)			-		
	flange	-			Ductile iron EN-GJS-400-18-LT (GGG 40.3)		
Valve seat		Stainless steel, mat. No. 1.4571					
Valve cone		Dezincing free brass CuZn36Pb2As					
Sealing		EPDM					
Pressure relieve system		Piston					

Actuator

Type	AVA	
Actuator size	cm ²	54
Nominal pressure	PN	25
Pressure setting ranges and spring colours	bar	1,0-4,5
		3-11
Materials	Upper casing of diaphragm	Stainless steel, mat. No.1.4301
		Lower casing of diaphragm
Diaphragm		EPDM
Impulse tube		Copper tube Ø6 × 1 mm

Application principles

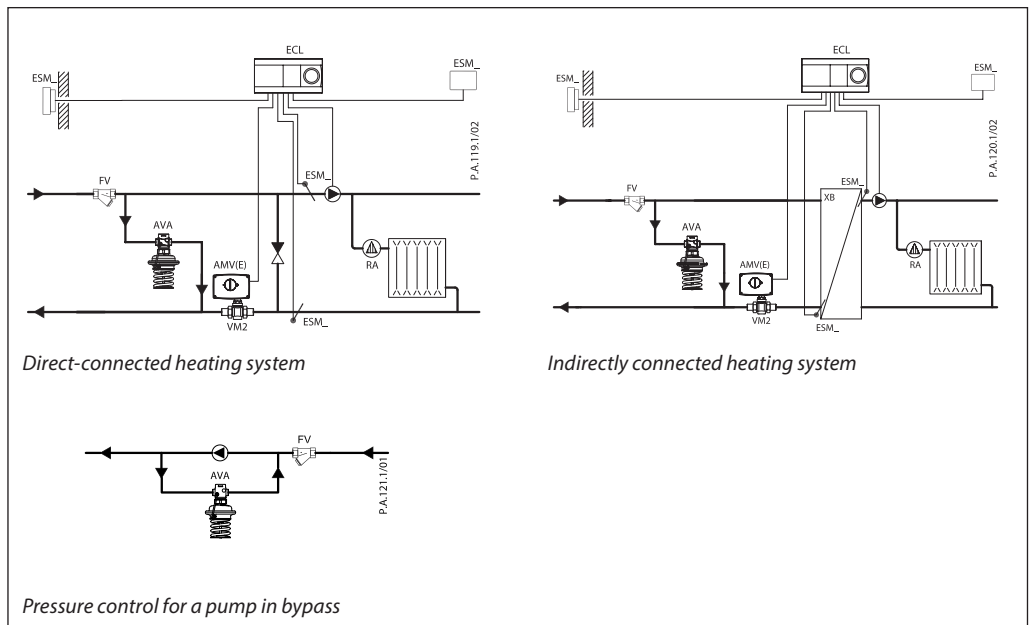

Installation positions

Up to medium temperature of 100 °C the controllers can be installed in any position.

For higher temperatures the controllers have to be installed in horizontal pipes only, with a pressure actuator oriented downwards.

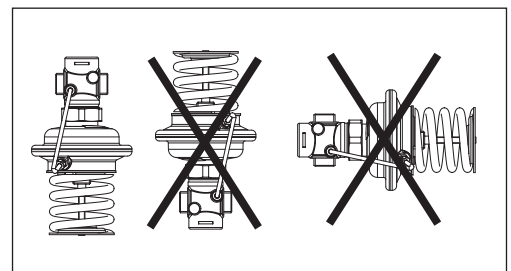
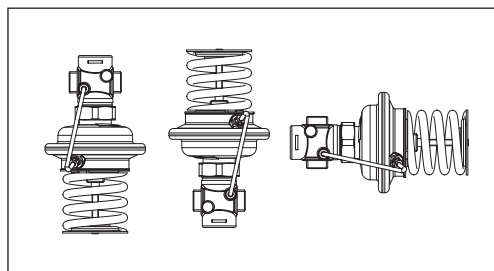

Pressure temperature diagram

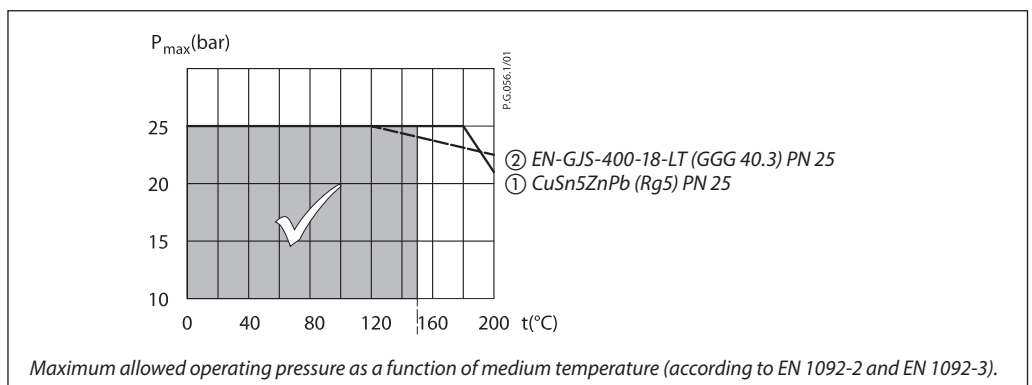

Sizing

Given data:

$$Q_{\max} = 1,9 \text{ m}^3/\text{h}$$

$$\Delta p_{\min} = 1,3 \text{ bar}$$

Nominal pressure PN 25

k_v value is calculated according to formula:

$$k_v = \frac{Q_{\max}}{\sqrt{\Delta p_{\min}}} = \frac{1,9}{\sqrt{1,3}}$$

$$k_v = 1,7 \text{ m}^3/\text{h}$$

Solution:

The example selects AVA DN 15, k_{vS} value 4,0, with pressure setting range 1,0-4,5 bar.

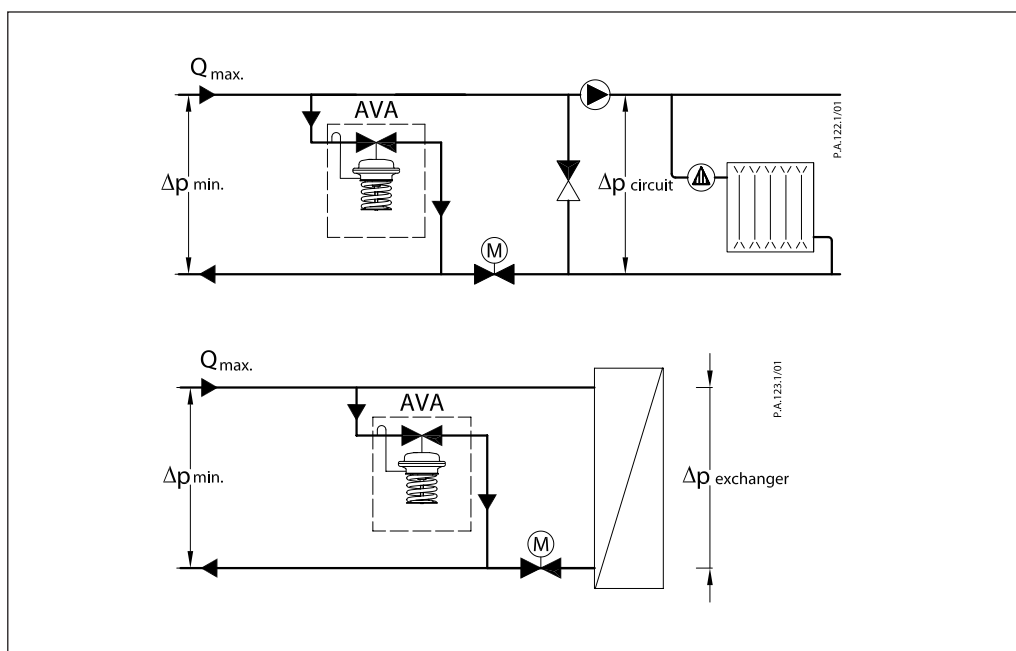

Design

- 1. Valve body
- 2. Valve insert
- 3. Pressure relieved valve cone
- 4. Valve stem
- 5. Control diaphragm
- 6. Setting spring for pressure control
- 7. Adjuster for pressure setting, prepared for sealing
- 8. Union nut
- 9. Upper casing of diaphragm
- 10. Lower casing of diaphragm
- 11. Air space bore
- 12. Impulse tube
- 13. Compression fitting for impulse tube
- 14. Actuator

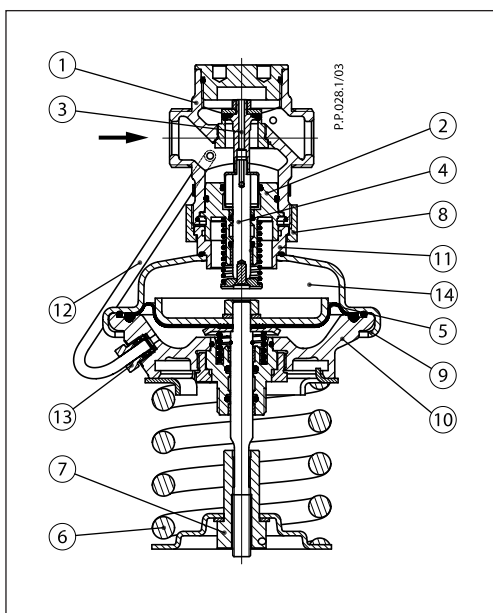

Function

The pressure in front of the control valve is being transferred through the impulse tube to the actuator chamber and act on control diaphragm. On the other side of the diaphragm atmospheric pressure is acting (through air space bore). Control valve is normally closed. It opens on rising pressure and closes on falling pressure to maintain constant pressure.

Settings

Pressure setting
 Pressure setting is being done by the adjustment of the setting spring for pressure control. The adjustment can be done by means of spring for pressure setting and/or pressure indicators.

Dimensions

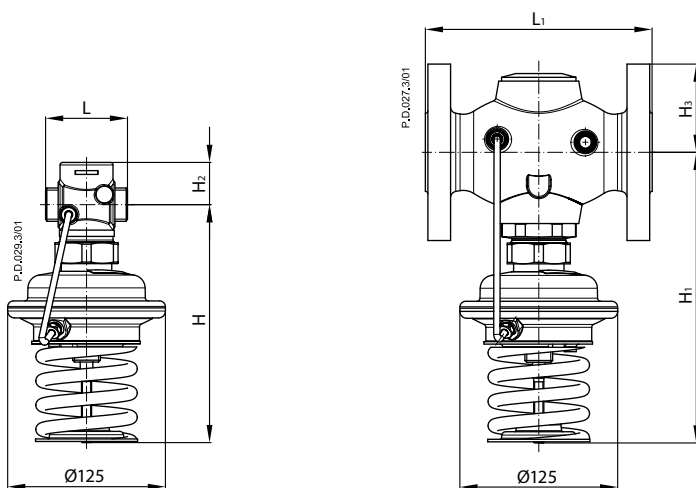

DN 15-25
Δp = 1,0-4,5 bar

DN 32-50
Δp = 1,0-4,5 bar

DN	L	L1	H	H1	H2	H3	Weight (kg)
15	65	-	188	-	34	-	3,5
20	70	-	188	-	34	-	3,5
25	75	-	188	-	37	-	3,7
32	-	180	-	231	-	70	10,4
40	-	200	-	231	-	75	12,0
50	-	230	-	231	-	82	13,9

Note: Other flange dimensions - see table for tailpieces.

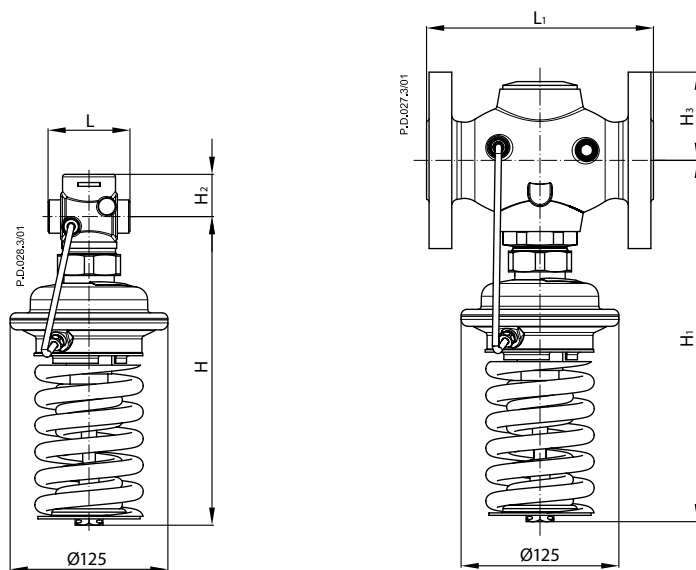

DN 15-25
Δp = 3,0-11 bar

DN 32-50
Δp = 3,0-11 bar

DN	L	L1	H	H1	H2	H3	Weight (kg)
15	65	-	243	-	34	-	3,7
20	70	-	243	-	34	-	3,7
25	75	-	243	-	37	-	3,9
32	-	180	-	287	-	70	10,5
40	-	200	-	287	-	75	12,1
50	-	230	-	287	-	82	14,0

Note: Other flange dimensions - see table for tailpieces.

Dimensions (continuous)

