

Data sheet

Liquid Level Switch

Type LLS 4000/4000U



The LLS 4000/4000U liquid level switch is designed to detect the state (gas or liquid) of the refrigerant in front of the sensing head, while installed in a wide range of refrigeration applications.

The LLS level switch comes in 2 variants, LLS 4000 and LLS 4000U. They are identical except for the connector thread interface to the system. The LLS 4000 is provided with G 3/4" thread, while the LLS 4000U is provided with NPT 3/4" thread.

The LLS 4000/4000U liquid level switch is based on the proven reflectometry measuring technology (microwave level measurement) adapted specifically for the new LLS 4000/4000U switch.

LLS 4000/4000U liquid level switches can be used to control the liquid level of many different refrigerants in vessels, accumulators, receivers, standpipes, etc. The switches are normally installed in a pair of two, controlling the upper liquid level and the lower liquid level.

The level switch includes a relay that switches by change in refrigerant state. The on site configuration of the LLS allows the normally open/closed relay setting depending on the desired correlation.

For SIL applications a SIL2 version is available with blocked configuration (not configurable).

All configuration and readings from the LLS switch are performed through Bluetooth and a downloadable special Danfoss app.

Features

- Plug and play liquid level switch
- Easy installation and minimum or no need for configuration
- Convenient communication with all units via Bluetooth and a Danfoss app
- SIL2 compliant version
- Two commonly used connection variants
- Maintenance free
- Replacement of electronic part without removing mechanical part (no opening to refrigerant)
- Applicable for ammonia and commonly used H(C)FCs
- Well proven reflectometry measuring principle
- Approvals: CE, PED, EMC, RED, ROHS, SIL2, FCC, (EAC, IC pending)
- Conforms to:
 - Telecommunications Directive RED 2014/53 EU.
 - Low voltage directive 2014/35/EU.
 - EMC directive 2014/30/EU.
 - ROHS 2011/65/EU

Contents	Features	1
	Product concept/applications	3
	Connection types	4
	Measuring principle	4
	Electrical installation/connection	5
	LED light indicators	5
	Configurable parameters	5
	Ordering	7
	Dimensions and weights	7
	Maintenance/service & calibration precautions	8
	Bluetooth communication	8
	Bluetooth configuration	9
	Technical data	10
	Safety/Approvals	11

**Product concept/
applications**

To control if a liquid level is within predefined allowed limits, two LLS 4000 are installed in an upper and a lower limit position respectively. By this setup the liquid level is between the two level switches and the lower switch will sense liquid, while the upper will sense gas.

In case the liquid level moves outside the limits, one of the switches will sense opposite and switch the built-in relay. This relay switch function should be used for alarm settings. This is made easy when connected to the system PLC.

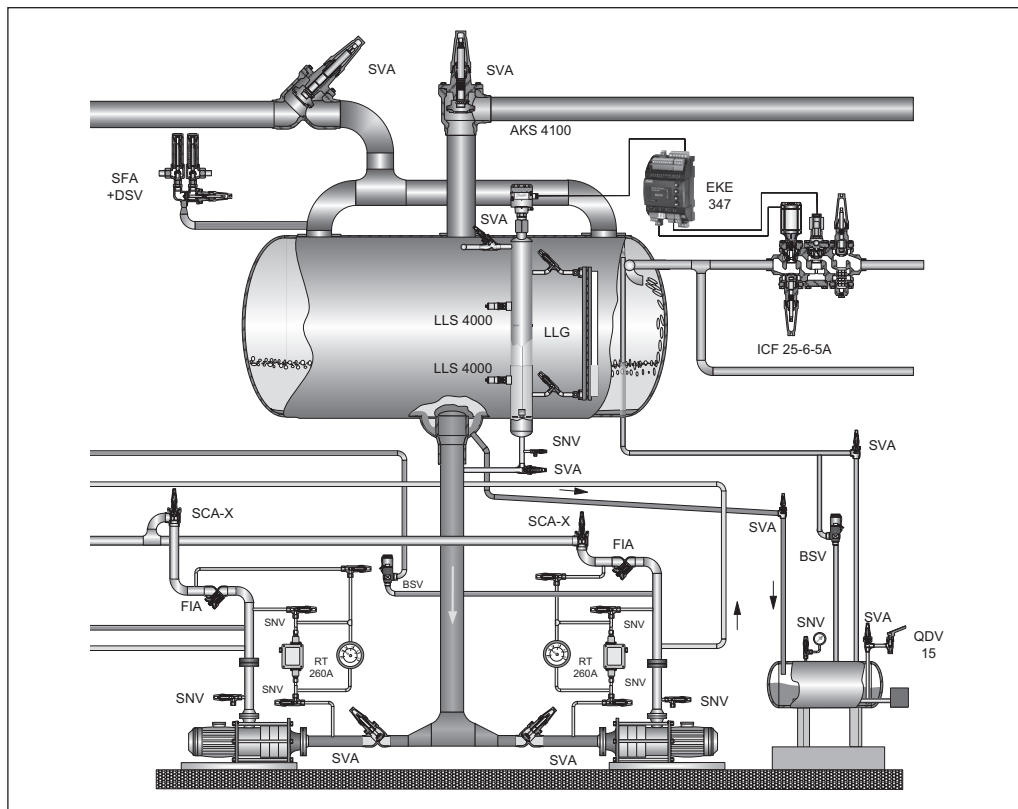

The LLS can be used wherever liquid levels of ammonia and certain H(C)FC refrigerants must be controlled.

The LLS comes in two versions:

- A standard version, which is applicable for most refrigeration or processing plants, and is fully configurable regarding type of liquid and relay setting.
- A SIL2 version applicable for SIL compliant process plants. This version is non-configurable regarding relay setting (see section: Configurable parameters) and is intended specific as the **upper** level switch.

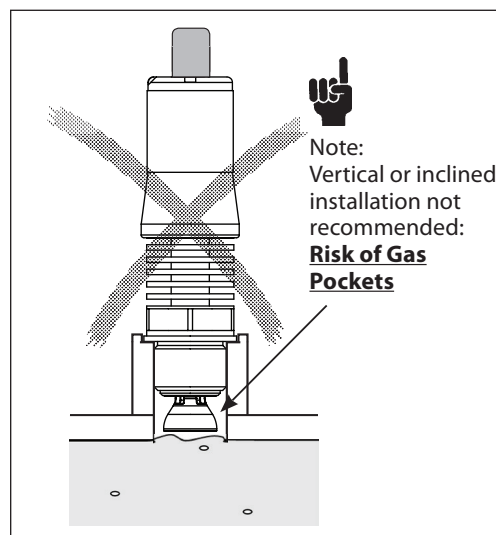
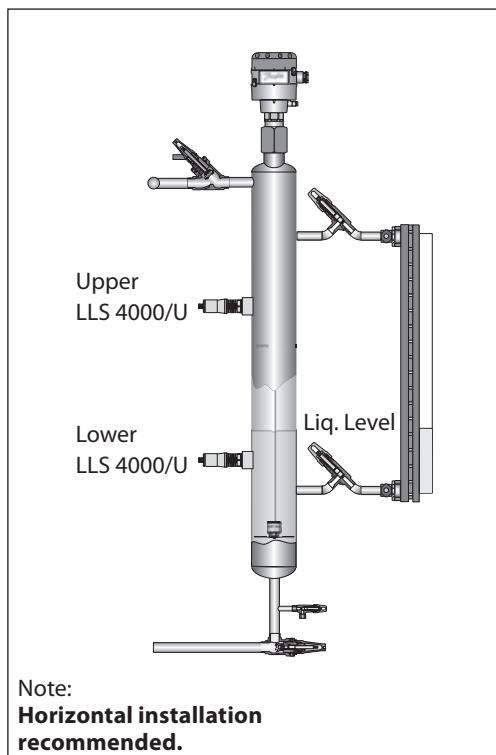

Connection types

Beside the two versions the LLS also comes with two different thread types, LLS 4000 and LLS 4000U. They are identical except for the connector thread for installation to the system. The LLS 4000 is provided with G 3/4" thread, while the LLS 4000U is provided with NPT 3/4" thread.

For connection to the actual part of the system appropriate weld connectors are needed. NPT connectors are widespread available, while Danfoss offers weld connectors for G 3/4" thread as accessory. Please note geometric restrictions below.

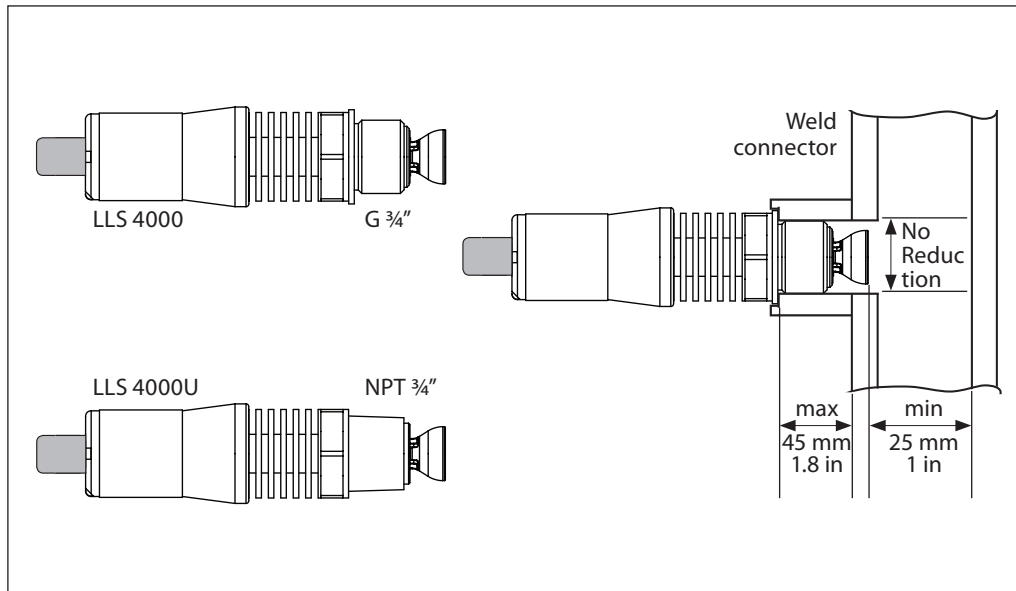

Measuring principle

The measurement principle of the LLS is based on reflectometry with a 4.9 GHz to 6.2 GHz linear sweep (Microwave switch technology). The reflected signal is characterized by a resonance frequency. The resonance frequency in air is taken as a reference (f_{ref}). When the sensing element is in contact with the liquid, the resonance frequency is shifting to a lower frequency. This is due to the change of the dielectric constant of the medium.

The point level switch monitors the resonance frequency and indicates whether the sensing element is surrounded by liquid or gas. The figure below shows the reference frequency with air (dielectric constant $\epsilon_r=1$) in front of the sensing element and with a liquid dielectric constant $\epsilon_r > 1.35$.

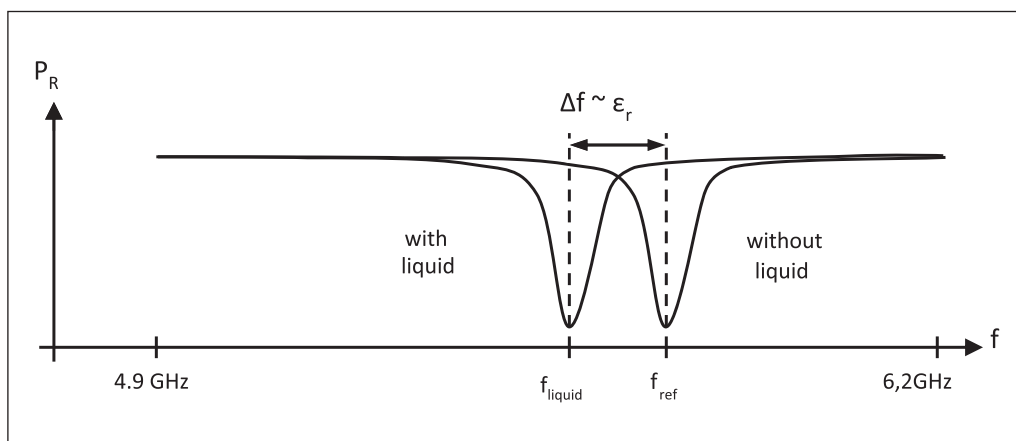

**Electrical installation/
connection**

The LLS 4000 level switch must be installed as one unit (mechanical and electrical assembled) without disassembly to avoid the need for recalibration.

For powering the device, a low power source (LPS) must be used with safety extra low voltage output (SELV) and current limited to 8A maximum.

After connecting the M12 female cable to the power supply and relay circuit the M12 plug can be installed on the M12 male connector and the power can be switched on.

At this stage the green light LED will turn on and be visible through the transparent housing.

The LLS is now ready for configuration via the Danfoss Bluetooth app (see section: Configurable parameters).

Danfoss M12 cables (ordered separately)
M12 cable female x 2 meter
M12 cable female x 8 meter

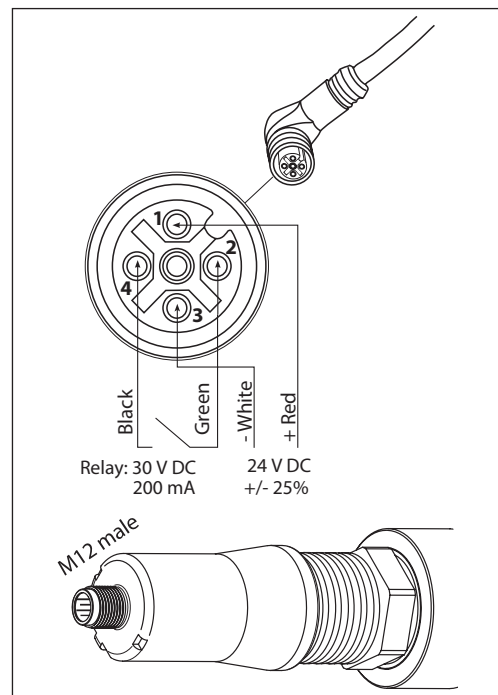
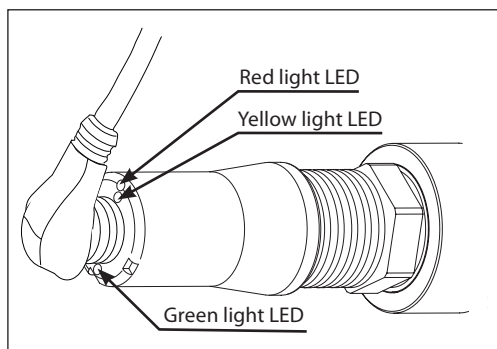

LED light indicators

There are three LED indicators inside the LLS 4000 behind the transparent cover.

- Green indicates the state of power to the switch.
 - If flashing: Bluetooth connection is established
- Yellow indicates if liquid is in front of switch.
- Red indicates if alarm is present.

Configurable parameters

The set-up of the LLS 4000 is easy and simple, since only few parameters in the LLS software are configurable. These are:

- Media type - Ammonia or Freon (H(C)FC).
Factory default: Ammonia
- Relay NO (normally open) or NC (normally closed)
Factory default: Normally closed

For plants where factory defaults are valid, the installation and set-up is simply Plug & play.

Below table shows possible configurations, relay state for given configuration/liquid level and LED indications.

	Level	LLS 4000/4000U NO mode*	LLS 4000/4000U NC mode*	Voltage connected	Level detection	LLS Fault
				Green LED	Yellow LED	Red LED
High Level sensor						
High Level sensor						
Low Level sensor						
Low Level sensor						
Voltage supply outside spec.	-					
LLS 4000/4000U fault**	-				***	

* Configuration dependent. Non-SIL2 fully configurable. SIL2 fixed configuration and only applicable for High Level sensor

** For failure types please connect the device to the Bluetooth App, enter fault state mode, and read the failure type

*** Fault can be detected at any detected level, ie. two or all three lights on

Ordering

LLS 4000/4000U

Description	Code Number
LLS 4000 liquid level switch (excl. welding connector & M12 cable) G 3/4"	084H6001
LLS 4000 SIL2 liquid level switch (excl. welding connector & M12 cable) G 3/4"	084H6002
LLS 4000U liquid level switch (excl. welding connector & M12 cable) NPT 3/4"	084H6003
LLS 4000U SIL2 liquid level switch (excl. welding connector & M12 cable) NPT 3/4"	084H6004

Spare parts/Accessories

Description	Code Number
Weld connector G 3/4"	084H6012
LLS 4000/U Electronic top part, non SIL2	084H6010
M12 Danfoss female cable, 2 meter (6.6 ft)	034G7073
M12 Danfoss female cable, 8 meter (26.2 ft)	034G7074
LLS 4000/U Inspection sealing kit	084H6011

Dimensions and weights

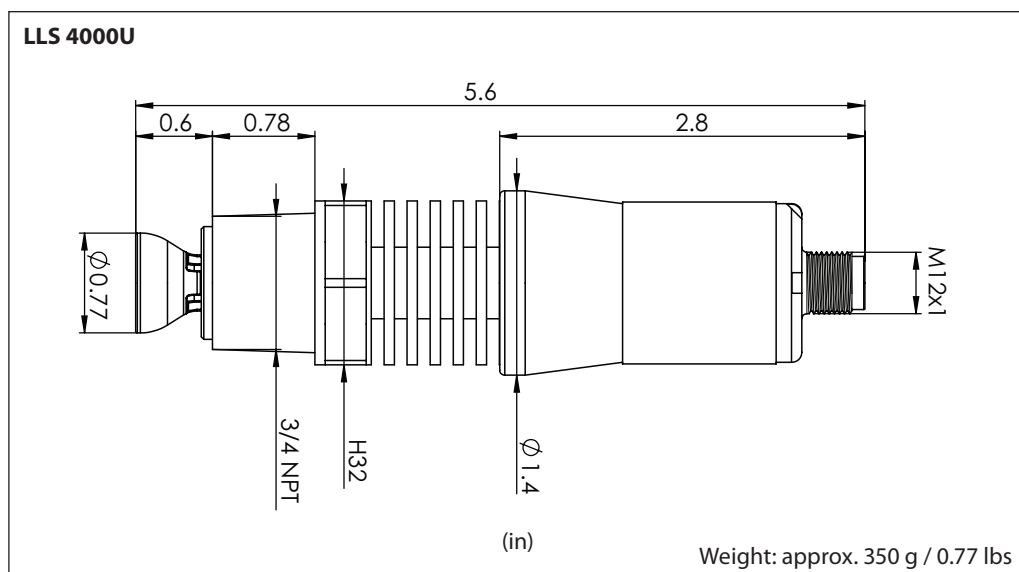
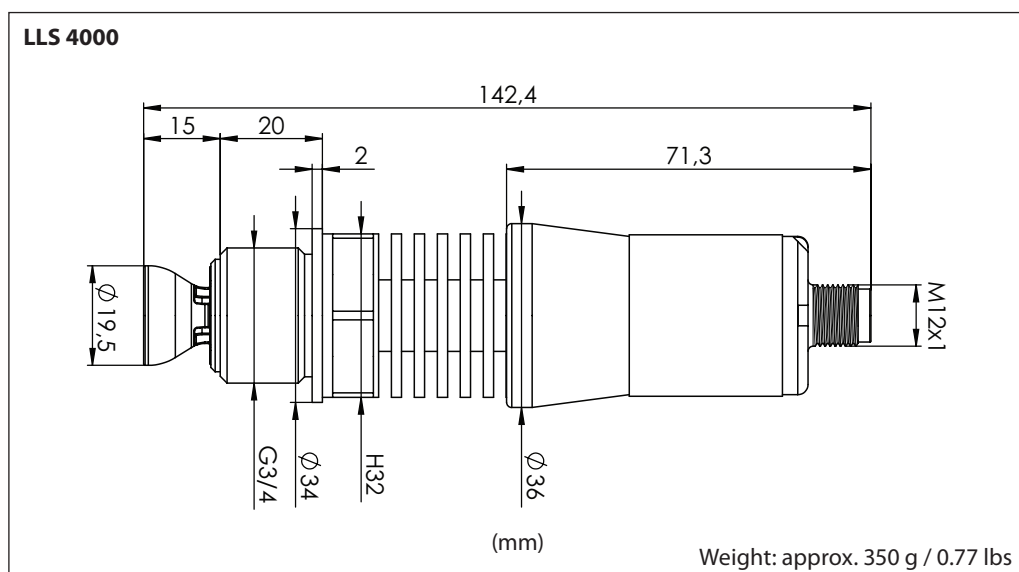

Maintenance/service & calibration precautions



The LLS 4000 is considered maintenance free, but there are a few precautions that needs attention.

The fins shall be kept free of dirt, dust, paint and oil etc. that potentially reduces the thermal heat transfer from the fins to the air.

For LLS cleaning use soft cloth dry or wet or compressed air.

If the electronic part is separated from the mechanical part during installation, service or maintenance, the ingress of any foreign substances to the electronic or mechanical part shall be avoided.

Generally the separating of electronic and mechanical parts should be avoided due to calibration, and the mixing of mechanical and electronic parts from different switches must be avoided. In case of the incident mixing of mechanical and electronic parts from different switches, subsequent recalibration might be required.

Prior to calibration the following must be ensured:

The LLS must be out of liquid state (in gas phase), otherwise the calibration might end up incorrect.

This can be secured by either emptying the actual vessel or uninstall the LLS to ambient air.

While in "dry" surroundings, connect power to the LLS switch and perform the calibration.

The danfoss LLS app includes the calibration possibility.

Ice build-up on the LLS switch reduces the accessibility for the Bluetooth connection.

- 10 cm icecap reduces the distance from app device to the LLS to 1 meter.

- 20 cm icecap is considered as the maximum to be able to connect.

Ice as such do not impact the functionality of the product as far as the minimum ambient temperature is respected.

Bluetooth communication

- A special Danfoss LLS app can be downloaded from Android google play or IOS app store.

- All communication with all LLS installed in a plant is done by use of this app. Communication can only happen with one LLS at a time.

- Each LLS switch includes its own serial number, which will appear in the app when connected. At the same time the green light LED in the actual connected LLS will be flashing.



Bluetooth® word mark and logos are registered trademarks of Bluetooth SIG Inc.

Android and Google Play are registered trademark of Google LLC. App Store is registered trademarks of Apple Inc.



Bluetooth configuration

The first time parameter setting of an individual LLS switch is done by opening of the app and performing a scan for devices. The app will get a list of LLS that are present at the actual location. The list will include a name and the matching serial number for each of the present LLS.

The name and configurable parameters of any LLS can be changed at any time.

1. Choose the first item on the list and observe which LLS' green LED is flashing
2. Log-in with the provided PIN code.
(For safety reason the PIN code should be changed afterwards)
3. Touch the Menu Icon
4. Touch the Log-in
5. Enter the Password provided
6. Rename the device to an up to 24 symbol name (8 symbols displayed)
7. Check the parameter settings and if needed change one or both parameters Media type/ Switch state
8. Note the ID: Name, serial number, media type and switch state
9. Close the app and observe that the green light stops flashing
10. This LLS is now ready for operation
11. If more LLS are present choose the next item on the list and repeat steps 1 to 10

Technical data

Electrical data	
Supply	24 V DC +/-25%, 80 mA Low power source (LPS) must be used with safety extra low voltage output (SELV) and current limited to 8 A maximum
Relay (Solid state)	30 V DC max., 200 mA. Use only safety extra low voltage (SELV). Functionally isolated from supply Max. cycles: 1.000.000 Maximum response time: 2 seconds
Overvoltage category	Category II for supply and output
Electrical connection	M12 (4 pins) male on the device
Measuring technology	Microwave reflectometry
Communication option	Bluetooth comply to ETSI EN 300 328
Mechanical Data	
Max. medium viscosity	5000 cps
Max. working pressure	65 bar (943 psi)
Ambient temperature range	-40 °C to +65 °C (-40 °F to +149 °F)
Medium temperature range	-50 °C to +120 °C (-58 °F to +248 °F)
Operating environment	Pollution degree 3, altitude 2000 max., outdoor use Relative humidity RH4 to RH99 % (IEC 60721-3-4: 1995 Class 4K4)
Connection type	G 3/4" or NPT 3/4"
Weight	350 g (0.77 lb)
Enclosure rating	IP 66/IP 67 IEC 60529: 1989 + A1: 1999 + A2: 2013 NEMA 250: 4X (pending)
Housing material (electronics)	Transparent and UV resistant. Compliance with IEC 60695-11-10, UL 94 HB
Housing material (mechanics)	Stainless Steel 316L
Approved media	
Refrigerants	R717/NH ₃ (Ammonia): -50 °C to +105 °C (-58 °F to +221 °F)
	R22: -50 °C to +86 °C (-58 °F to +187 °F)
	R404A: -50 °C to +63 °C (-58 °F to +145 °F)
	R410A: -50 °C to +61 °C (-58 °F to +142 °F)
	R134A: -50 °C to +91 °C (-58 °F to +196 °F)
EU conformity	
Radio Equipment Directive (RED) 2014/53/EU	EN 300 328 V2.1.1 EN 62311: 2008
Low voltage directive 2014/35/EU	EN 61010-1 (edition III)
EMC directive 2014/30/EU	EN 61326-1: 2013
PED	2014/68/EU, A4P3.
ROHS 2011/65/EU	2011/65/EU 2015/863/EU
Approvals	CE: PED, EMC, RED, RoHS, LVD SIL2 FCC EAC (pending) IC (pending)

Safety/Approvals



Warning! This is a Class A device. This device may cause radio interference in residential areas. In case of interference, the operator may be required to take appropriate measures. This instrument has to be mounted on a metallic tank. The device is intended to be used in industrial areas.

General Warnings/precautions

- Every use that is not described in this data sheet is considered incorrect and is not authorized by the manufacturer.
- The LLS device should only be used with approved media listed under Technical data. Use with other media must be validated by Danfoss before installation.
- Verify that the installation and operating conditions of the device respect those specified in this sheet, especially concerning the supply voltage and environmental conditions.
- All service and maintenance operations must be performed by qualified personnel.
- Installation must comply with local standards and legislation.
- Before carrying out any maintenance operations on the device, disconnect the device from the main power supply.
- Before unscrewing the LLS device from the pipe or tank ensure that pipe or tank is empty and not under pressure.
- Liability for injury or damage caused by incorrect use of the device lies solely with the user.
- Depending on the application, the metallic part of the instrument may be hot or cold.
- If media detection or non-detection by the level switch could generate a hazard the SIL version and specific instructions described in the safety manual (periodic proof test) should be used. The SIL safety manual can be downloaded from the Danfoss web site.

- (1) this device may not cause harmful interference, and
- (2) this device must accept any interference received, including interference that may cause undesired operation.

This equipment has been tested and found to comply with the limits for a Class A digital device, pursuant to Part 15 of the FCC Rules. These limits are designed to provide reasonable protection against harmful interference when the equipment is operated in a commercial environment. This equipment generates, uses, and can radiate radio frequency energy and, if not installed and used in accordance with the instruction manual, may cause harmful interference to radio communications. Operation of this equipment in a residential area is likely to cause harmful interference in which case the user will be required to correct the interference at his own expense.

Under Industry Canada regulations, this radio transmitter may only operate using an antenna of a type and maximum (or lesser) gain approved for the transmitter by Industry Canada. To reduce potential radio interference to other users, the antenna type and its gain should be so chosen that the equivalent isotropically radiated power (e.i.r.p.) is not more than that necessary for successful communication.

This device complies with FCC and ISED RF radiation exposure limits set forth for general population. This device must be installed to provide a separation distance of at least 20 cm from all persons and must not be co-located or operating in conjunction with any other antenna or transmitter.

The Product Marketing name of the instrument is 'LLS 4000 series'.

USA/Canada:



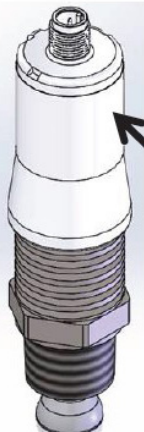





This device complies with Part 15 of the FCC Rules and with RSS-210 of Industry Canada. Operation is subject to the following two conditions.



XXXXXXXXXXXXXXXXXXXX
XXXXXXXXXX



S/N: XXXXXXXXXXXXXXXXXXXX
Supply: 24 V DC --- 80 mA
Connection type: XXXXXXXX / XXXX
MWP (PS): 65 bars
Process temp.: -50°C to +120°C
MD: XXXX/XX
FCC ID: Q68SWSILBT01
IC: 1991D-SWSILBT01

IP66/IP67
PV01
CMIIT: XXXXXXXXXXXXX

Danfoss
MADE IN FRANCE
lib. nr. FZ-4007312201

Danfoss A/S, 6430 Nordborg, Denmark

 → 

Read and apply safety instructions contained in product documentation.

Direct current.

Contact : Danfoss A/S, 6430 Nordborg, Denmark

