

Data sheet

# Shut-off diaphragm valve

## Types BML and BMT



BML are manual shut-off diaphragm valve designed for installation in the liquid, suction and hot gas lines of refrigeration plants. BML valves can be delivered with flare, ODF solder or ODF solder with extended ends.

In the same product category, BMT 6 is a three-way manual shut-off valve with similar characteristics.

### Features

- Fitted with three stainless steel diaphragms that prevent leakage throughout the operating life of the valve.
- Valve plate of polyamide nylon to give complete shut-off with minimum torque.
- Valve cover with counter-seat to prevent the ingress of moisture.
- Solder versions are compliant with ATEX hazard zone 2.

**Technical data**

<b>Refrigerants</b>	R134a, R22/R407C, R404A/R507, R32, R290, R600, R600a, R1270, R513A, R450A, R1234ze, R1234yf. For complete list of approved refrigerants, go to <a href="http://products.danfoss.com/all-products/">http://products.danfoss.com/all-products/</a>
<b>Media Temperature range</b>	-55 – 100 °C / -67 – 212 °F
<b>Working range</b>	$\Delta p = -1 - 21 \text{ bar} / -14 - 304 \text{ psig}$
<b>Max. working pressure</b>	PS/MWP = 28 bar / 406 psig
<b>Max. test pressure</b>	Pe = 46 bar / 667 psig



**Note:** Only solder versions are allowed for flammable refrigerant.  
This product is approved for R290, R600, R600a and R1270 by ignition source assessment in accordance to standard EN13463-1.

**Approvals**

**Ordering**
**Straightway version with hand wheel**

Type	Connection size		K <sub>v</sub> value (calculate)	C <sub>v</sub> value (calculate)	Code no.
	[in.]	[mm]	[m <sup>3</sup> /h]	[gal/min]	

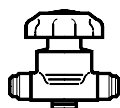
**BML with flare connections**

Flare

BML 6	1/4	-	0.3	0.35	009G0101
BML 10	3/8	-	0.84	0.98	009G0127
BML 12	1/2	-	1.5	1.75	009G0141
BML 15	5/8	-	2.2	2.57	009G0168
BML 18	3/4	-	2.9	3.38	009G0183

**BML with ODF solder connections**

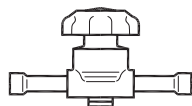

ODF solder

BML 6s	1/4	-	0.3	0.35	009G0102
	-	6	0.3	0.35	009G0108
BML 10s	3/8	-	0.84	0.98	009G0122
	-	10	0.84	0.98	009G0128
BML 12s	1/2	-	1.5	1.75	009G0142
	-	12	1.5	1.75	009G0148
BML 15s	5/8	16	2.2	2.57	009G0170
BML 18s	3/4	-	2.9	3.38	009G0181
	-	18	2.9	3.38	009G0184
BML 22s	7/8	22	2.9	3.38	009G0191

**BML with extended ODF solder connections**

ODF extended ends

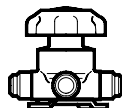
BML 6s	1/4	-	0.3	0.35	009G0202
	-	6	0.3	0.35	009G0208
BML 10s	3/8	-	0.84	0.98	009G0222
	-	10	0.84	0.98	009G0228
BML 12s	1/2	-	1.5	1.75	009G0242
	-	12	1.5	1.75	009G0248
BML 15s	5/8	16	2.2	2.57	009G0262
BML 22s	7/8	22	2.9	3.38	009G0291

**Threeway version with hand wheel**

Flare

Type	Connection size		K <sub>v</sub> value (calculate)	C <sub>v</sub> value (calculate)	Code no.
	[in.]	[mm]	[m <sup>3</sup> /h]	[gal/min]	

**BMT with flare connections**

BMT 6	1/4	-	0.3	0.35	009G0105
-------	-----	---	-----	------	----------

Design / Function

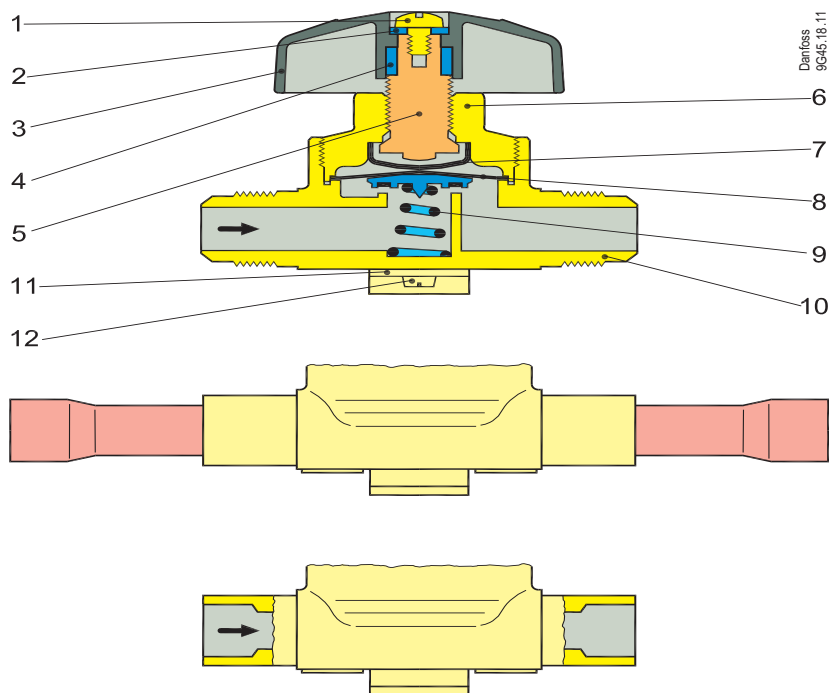

Danfoss  
9C45.18.11

- 1. Screw
- 2. Washer
- 3. Handwheel
- 4. Driver
- 5. Spindle
- 6. Cover
- 7. Thrust pad
- 8. Diaphragm with valve plate
- 9. Spring
- 10. Valve body
- 11. Bracket
- 12. Screw

The shut-off diaphragm valves are fitted with three diaphragms of stainless steel which ensure long operating life. BM valves are available in straightway, and three-way versions (BMT). The side connection of the three-way BMT can be shut off, but the end connections will always remain open. The BM can be fitted with a mounting bracket. Valve body, cover and spindle are made of brass, the handwheel (3) of coloured plastic. BM valves have a triple diaphragm seal (8) which is designed in such a way that the tension in the diaphragms lift the valve plate from the seat when the valve is opened.

The valve plate itself is made of nylon and gives complete shut-off when the handwheel is lightly tightened. The thrust pad (7) prevents direct contact between spindle (5) and diaphragms (8). This also contributes to increased valve life. The spring (9) is able to hold the valve open at operating pressures down to -1 bar (pe). The counter-seat in the cover (6) prevents the ingress of moisture in fully open position. When the valve is opened, the pressure on the outlet side must not exceed the pressure on the inlet side by more than 1 bar.

Dimensions and weights

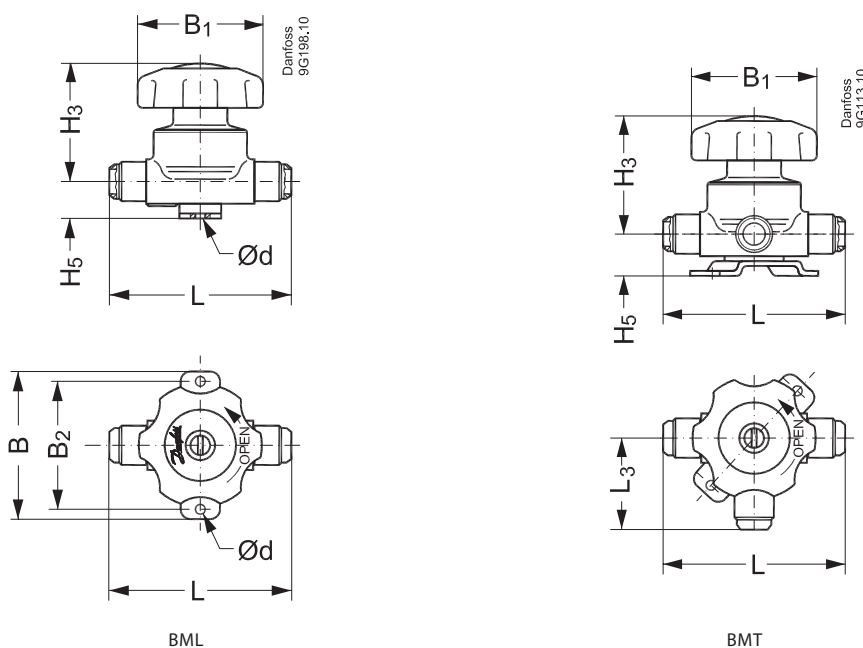

Flare version - SI Units

Type	H <sub>3</sub> [mm]	H <sub>5</sub> [mm]	L [mm]	L <sub>3</sub> [mm]	B [mm]	B <sub>1</sub> [mm]	B <sub>2</sub> [mm]	Ød [mm]	Net weight [g]
<b>BML 6</b>	46	15	77	–	62	50	50	5	290
<b>BML 10</b>	49	15	85	–	62	50	50	5	328
<b>BML 12</b>	56	18	102	–	70	60	56	6	568
<b>BML 15</b>	66	19	118	–	83	71	69	6	846
<b>BML 18</b>	66	24	130	–	83	71	69	6	1294
<b>BMT 6</b>	46	19	65	32.5	62	50	50	5	290

Flare version - US Units

Type	H <sub>3</sub> [in.]	H <sub>5</sub> [in.]	L [in.]	L <sub>3</sub> [in.]	B [in.]	B <sub>1</sub> [in.]	B <sub>2</sub> [in.]	Ød [in.]	Net weight [lbs]
<b>BML 6</b>	1.81	0.59	–	–	2.44	1.97	1.97	0.20	0.639
<b>BML 10</b>	1.93	0.59	–	–	2.44	1.97	1.97	0.20	0.723
<b>BML 12</b>	2.20	0.71	4.02	–	2.76	2.36	2.20	0.24	1.252
<b>BML 15</b>	2.60	0.75	4.65	–	3.27	2.80	2.72	0.24	1.865
<b>BML 18</b>	2.60	0.94	5.12	–	3.27	2.80	2.72	0.24	2.86
<b>BMT 6</b>	1.81	0.75	2.56	1.28	2.44	1.97	1.97	0.20	0.639

Dimensions and weights

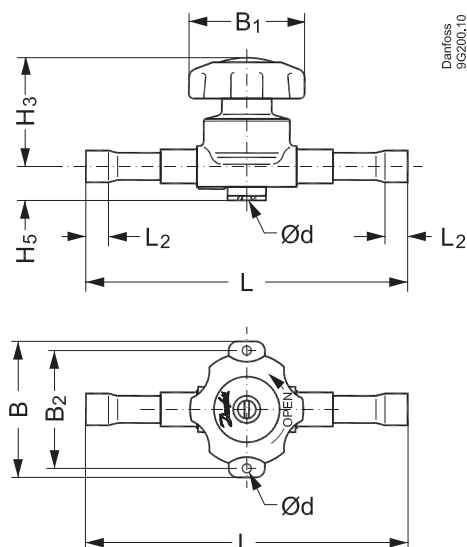

ODF solder extended ends version - SI Units

Type	H <sub>3</sub> [mm]	H <sub>5</sub> [mm]	L [mm]	L <sub>3</sub> [mm]	B [mm]	B <sub>1</sub> [mm]	B <sub>2</sub> [mm]	Ød [mm]	Net weight [g]
BML 6s	46	17	117	7	62	50	50	5	282
BML 10s	49	16	117	9	62	50	50	5	312
BML 12s	55	18	128	10	70	60	56	6	522
BML 15s	66	20	165	12	83	71	69	6	816
BML 22s	66	22	181	17	83	71	69	6	902

ODF solder extended ends version - US Units

Type	H <sub>3</sub> [in.]	H <sub>5</sub> [in.]	L [in.]	L <sub>3</sub> [in.]	B [in.]	B <sub>1</sub> [in.]	B <sub>2</sub> [in.]	Ød [in.]	Net weight [lbs]
BML 6s	1.81	0.67	4.61	0.28	2.44	1.97	1.97	0.20	0.622
BML 10s	1.93	0.63	4.61	0.35	2.44	1.97	1.97	0.20	0.687
BML 12s	2.17	0.71	5.04	0.39	2.76	2.36	2.20	0.24	1.150
BML 15s	2.60	0.79	6.50	0.47	3.27	2.80	2.72	0.24	1.798
BML 22s	2.60	0.87	7.13	0.67	3.27	2.80	2.72	0.24	1.988

Dimensions and weights

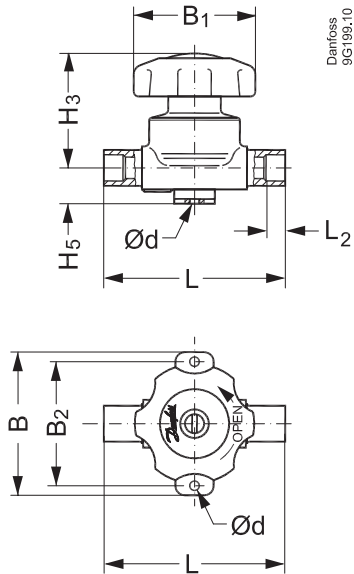

ODF solder version - SI Units

Type	H <sub>3</sub> [mm]	H <sub>5</sub> [mm]	L [mm]	L <sub>3</sub> [mm]	B [mm]	B <sub>1</sub> [mm]	B <sub>2</sub> [mm]	Ød [mm]	Net weight [g]
BML 6s	46	17	65	7	62	50	50	5	274
BML 10s	49	16	72	9	62	50	50	5	308
BML 12s	55	18	87	10	70	60	56	6	508
BML 15s	65	20	106	12	83	71	69	6	790
BML 18s	66	22	103	14	83	71	69	6	816
BML 22s	66	22	103	17	83	71	69	6	828

ODF solder version - US Units

Type	H <sub>3</sub> [in.]	H <sub>5</sub> [in.]	L [in.]	L <sub>3</sub> [in.]	B [in.]	B <sub>1</sub> [in.]	B <sub>2</sub> [in.]	Ød [in.]	Net weight [lbs]
BML 6s	1.81	0.67	2.56	0.28	2.44	1.97	1.97	0.20	0.604
BML 10s	1.93	0.63	2.83	0.35	2.44	1.97	1.97	0.20	0.679
BML 12s	2.17	0.71	3.43	0.39	2.76	2.36	2.20	0.24	1.120
BML 15s	2.56	0.79	4.17	0.47	3.27	2.80	2.72	0.24	1.741
BML 18s	2.60	0.87	4.06	0.55	3.27	2.80	2.72	0.24	1.799
BML 22s	2.60	0.87	4.06	0.67	3.27	2.80	2.72	0.24	1.825