

Data sheet

# Pressure transmitter for general purpose

## Type MBS 1700 and MBS 1750



The compact pressure transmitters MBS 1700 and MBS 1750 are designed for use as a general purpose transmitter, and offers a reliable pressure measurement, even under harsh environmental conditions.

The version MBS 1750 with integrated pulse-snubber is designed for use in applications with severe medium influences like cavitation, liquid hammer or pressure peaks and offers a reliable pressure measurement, even under harsh environmental conditions.

Excellent vibration stability, robust construction, and a high degree of EMC / EMI protection equip the pressure transmitter to meet the most stringent industrial requirements.

### Features

- Enclosure and wetted parts of acid-resistant stainless steel (AISI 316L)
- Pressure ranges in relative (gauge) from 0 – 25 bar
- Output signal: 4 – 20 mA
- Pressure connections:
  - G 1/4A & G 1/2A EN837 (MBS 1700)
  - G 1/4 DIN 3852-E, Gasket DIN 3869-15 (MBS 1750)
- Temperature compensated and laser calibrated

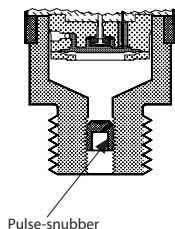
**Application and media conditions (MBS 1750)**

**Application**

Cavitation, liquid hammer and pressure peaks may occur in liquid filled systems with changes in flow velocity, e.g. fast closing of a valve or pump starts and stops.

The problem may occur on the inlet and outlet side, even at rather low operating pressures.

**Media condition**

Clogging of the nozzle may occur in liquids containing particles. Mounting the transmitter in an upright position minimizes the risk of clogging, because the flow in the nozzle is limited to the start-up period until the dead volume behind the nozzle orifice is filled.

The media viscosity has only little effect on the response time. Even at a viscosities up to 100 cSt, the response time will not exceed 4 ms.

**Technical data**
**Performance (EN 60770)**

Accuracy (incl. non-linearity, hysteresis and repeatability)	$\leq \pm 0.5\%$ FS (typ.)
	$\leq \pm 1.0\%$ FS (max.)
Non-linearity BFSL (conformity)	$\leq \pm 0.2\%$ FS
Hysteresis and repeatability	$\leq \pm 0.1\%$ FS
Thermal zero point shift	$\leq \pm 0.1\%$ FS/10K (typ.)
	$\leq \pm 0.2\%$ FS/10K (max.)
Thermal sensitivity (span) shift	$\leq \pm 0.1\%$ FS/10K (typ.)
	$\leq \pm 0.2\%$ FS/10K (max.)
Response time	< 4 ms
	Air and gases (MBS 1750) < 35 ms
Overload pressure (static)	6 × FS (max. 1500 bar)
Burst pressure	6 × FS (max. 2000 bar)
Durability, P: 10 – 90% FS	> 10 × 10 <sup>6</sup> cycles

**Electrical specifications**

Nom. output signal (short-circuit protected)	4 – 20 mA
Supply voltage [U <sub>s</sub> ], polarity protected	9 – 32 V d.c.
Supply – current consumption	–
Supply voltage dependency	$\leq \pm 0.1\%$ FS/10 V
Current limitation	28 mA (typ.)
Output impedance	–
Load [R <sub>L</sub> ] (load connected to 0 V)	$R_L \leq (U_s - 9 \text{ V})/0.02 \text{ A } [\Omega]$

**Technical data**

*Environmental conditions*

Sensor temperature range	Normal	-40 – 85 °C	
Max. media temperature		115 - (0.35 x ambient temp.)	
Ambient temperature range		-40 – 85 °C	
Compensated temperature range		0 – 80 °C	
Transport / storage temperature range		-50 – 85 °C	
EMC – Emission		EN 61000-6-3	
EMC – Immunity		EN 61000-6-2	
Insulation resistance		> 100 MΩ at 100 V	
Mains frequency test		Based on SEN 361503	
Vibration stability	Sinusoidal	15.9 mm-pp, 5 Hz-25 Hz 20 g, 25 Hz – 2 kHz	IEC 60068-2-6
	Random	7.5 g <sub>rms</sub> , 5 Hz – 1 kHz	IEC 60068-2-64
Shock resistance	Shock	500 g / 1 ms	IEC 60068-2-27
	Free fall	1 m	IEC 60068-2-32
Enclosure		IP65	

*Mechanical characteristics*

Materials	Wetted parts	EN 10088-1; 1.4404 (AISI 316 L)
	Enclosure	EN 10088-1; 1.4404 (AISI 316 L)
	Electrical connections	Glass filled polyamid PA 6.6
Net weight		0.25 kg

*Guideline for installations at high media temperature*

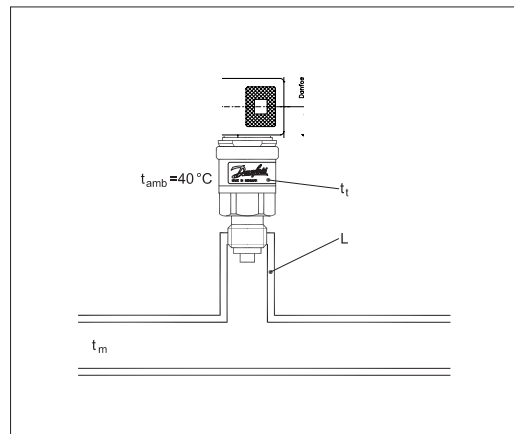

Medium temperature (t <sup>m</sup> ) 120 °C	
Heat isolator (L)	Transmitter temperature (t <sub>t</sub> )
2 cm	85 °C
5 cm	75 °C
10 cm	70 °C

**Data sheet | Pressure transmitter for general purpose, type MBS 1700 and MBS 1750**
**Ordering MBS 1700**
*Plug; Pg 9 (EN 175301-803-A)*

Measuring range P <sup>e1</sup> [bar]	Output signal	Pressure connection	Code No.
0 – 6	4 – 20 mA	G ¼ A EN 837	<b>060G6100</b>
0 – 10			<b>060G6101</b>
0 – 16			<b>060G6102</b>
0 – 25			<b>060G6103</b>
0 – 6		G ½ A EN 837	<b>060G6104</b>
0 – 10			<b>060G6105</b>
0 – 16			<b>060G6106</b>
0 – 25			<b>060G6107</b>

<sup>1)</sup> Relative / gauge

**Ordering MBS 1750**
*Plug; Pg 9 (EN 175301-803-A)*

Measuring range P <sup>e2</sup> [bar]	Output signal	Pressure connection	Code No.
0 – 60	4 – 20 mA	DIN 3852-E G ¼ Gasket DIN 3869-14	<b>060G6108</b>
0 – 100			<b>060G6112</b>
0 – 160			<b>060G6109</b>
0 – 250			<b>060G6110</b>
0 – 400			<b>060G6111</b>

<sup>2)</sup> Sealed gauge

Dimensions

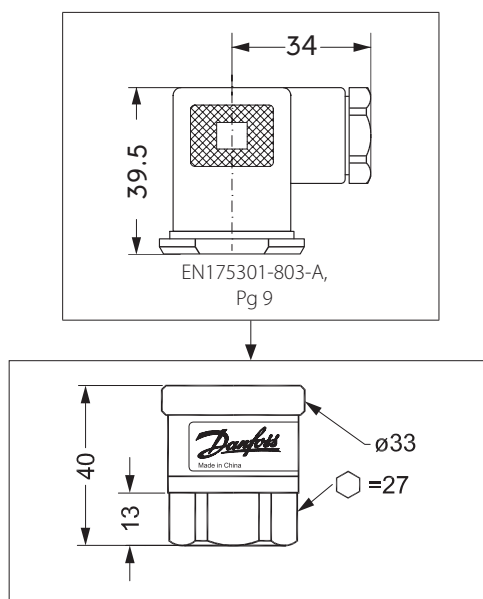

Type code	MBS 1700		MBS 1750
Recommended torque <sup>1)</sup>	30 – 35 Nm		30 – 35 Nm

<sup>1)</sup> Depends on different parameters as packing material, mating material, thread lubrication and pressure level

**Electrical connections**

Type code	1
	<p>EN 175301-803-A, Pg 9</p>
Ambient temperature	-40 – 85 °C
Enclosure (IP protection fulfilled together with mating connector)	IP65
Material	Glass filled polyamid, PA 6.6
Electrical connection, 4 – 20 mA output (2 wire)	<p>Pin 1: + supply Pin 2: ÷ supply Pin 3: Not used</p> <p>Earth: Connected to MBS enclosure</p>